

Datasheet

BRC1H52/82 Wired user interface with buzzer function and Bluetooth App

Table of Contents

1. Introduction	3
2. Overview of compatible Daikin units ranges.....	4
3. System layout.....	5
3.1 Typical layout.....	5
3.2 Typical layout for group control.....	5
3.2 Typical layout for group control (with optional sub UI or Digital Input Adapter board)	7
3.2.1 Main/Sub UI.....	7
3.2.2 Digital Input Adapter board	7
4. Specifications.....	8
4.1 Technical specifications.....	8
4.2 Available documentation.....	8
4.3 Outlook and dimensions	9
4.3.1 Outlook	9
4.3.2 Dimensions	9
4.4 Installation method.....	10
5 Summary of features	11
5.1 Basic user interface.....	11
5.2 Basic operation settings.....	11
5.3 R/C Interface Logic	12
5.4 Status and operation mode icons.....	12
5.4.1 Status icons.....	12
5.4.2 Operation mode icons.....	13
5.5 Advanced operation settings to be set by App.....	13
5.5.2 Clock function	14
5.5.3 Schedule timer function	14
5.5.4 Energy Saving features.....	14
5.5.5 Button lock	15
5.5.6 Maintenance information.....	15
5.5.7 Quiet Mode & Demand Control	15
5.5.8 Duty Rotation and Backup	16
5.6 Options.....	17
5.6.1 Digital Input Adapter Board (BRP7A51/52/53/54).....	17
5.6.2 Software Updater.....	17

5.7 Smartphone requirements, pairing, connection & features 18
 5.7.1 Apple iOS 8.0 or higher 18
 5.7.2 Android 5.0 or higher and Bluetooth Low Energy 4.2 or higher 18
6. Combination BRC1H51/81/519 & DIII central control equipment 19
7. Revision 23

1. Introduction

The wired user interface BRC1H52/82 allows the end user to control connected Daikin indoor units. The wired User Interface (UI) uses the P1P2 connection of the indoor unit to communicate.

A second UI can be connected to the same P1P2 connection. In this case one UI needs to be main and the other sub controller(*).

The BRC1H52/82 is the successor of the BRC1E*, BRC2E*, BRC3E* and BRC1H51/81/81*7/519/519*7. There were the BRC1E53 has one fits all interface, the BRC1H51/81/817/519/5197 has a split up interface which fits better the users:

- End user interface: European design, simplified, symbol driven, limited buttons, different colours
- Advance user and professional user: via App (Bluetooth low energy)

Towards BRC1H51/81/81*7/519/519*7 the BRC1H52/82 controller has a buzzer function to be used as legal requirement in combination with mini VRV R32 units

(*). The maximum wire length of P1P2 is limited to 500m

The BRC1H52/82 is not backwards compatible with the BRC1E*, BRC2E*, BRC3E* and BRC1H51/81/81*7/519/519*7

2. Overview of compatible Daikin units ranges

	Type	Model name	BRC1H51*	BRC1H519W/K/S	BRC1H81W/S	BRC1H519 W7,K7,S7	BRC1H81 W7,S7
SkyAir	Ceiling mounted cassette	FCAHG-F				0	0
		FCAHG-G				0	0
		FCQHG-F				0	0
		FCQG-F				0	0
		FCAG-A				0	0
		FCQ-EVM					0
		FFQ-C				0	0
	FFA-A				0	0	
	Concealed ceiling	FDBQ-B				0	0
		FDXS-F3				0	0
		FBQ-D				0	0
		FBQ-EVM					0
		FBA-A				0	0
		FDQ-C				0	0
		FDA-A				0	0
		FDQ-B				0	0
		ADEQ-C				0	0
		ABQ-C				0	0
	Wall mounted	FAQ-C9				0	0
		FAQ-B				0	0
	Ceiling suspended	FAA-A				0	0
		FHQ-CB				0	0
		FHA-A				0	0
		FUQ-C				0	0
		AHQ-C				0	0
	Floor standing	FUA-A				0	0
		FVQ-C				0	0
		FNQ-A				0	0
		FNQ-A				0	0
	Round flow Cassette(3x3)	ACQ-C				0	0
	Large duct	FDQ-B/C				0	0
	Air curtains	CYVQ				0	0
	VRV	Ceiling mounted cassette	FXFQ-A	0	0	0	0
FXFQ-P						0	0
FXZQ-A			0	0	0	0	0
FXCQ-A			0	0	0	0	0
FXKQ-MA			0	0	0	0	0
Concealed ceiling		FXDQ-M9	0	0	0	0	0
		FXDQ-A3	0	0	0	0	0
		FXDQ-A	0	0	0	0	0
		FXSQ-A	0	0	0	0	0
		FXMQ-P7	0	0	0	0	0
		FXMQ-PVE				0	0
		FXMQ-MB	0	0	0	0	0
		FXTQ-A	0	0	0	0	0
		FDXM-F3	0	0	0	0	0
		Wall mounted	FXAQ-P	0	0	0	0
FXAQ-PVE						0	0
Ceiling suspended		FXAQ-PVER1				0	0
		FXAQ-A	0	0	0	0	0
Floor standing		FXHQ-A	0	0	0	0	0
		FXUQ-A	0	0	0	0	0
		FXLQ-P	0	0	0	0	0
Duct-Small		FXNQ-A	0	0	0	0	0
Duct - Slim		FXDQ-M	0	0	0	0	0
Duct - Standard		FXDQ-P	0	0	0	0	0
Duct- high ESP		FXSQ-P	0	0	0	0	0
Floor standing- concealed		FXMQ-P/MA/PVE	0	0	0	0	0
Air curtains		FXNQ-P	0	0	0	0	0
		CYVM	0	0	0	0	0
RA	Slim duct	FDXS-F3	0	0	0	0	0
		FDXM-F3	0	0	0	0	0
VAM	Ventilation unit	VAM-FA/FB/FC/J	0			0	0
VKM	Ventilation unit	VKM-GB/GBM	0			0	0
ERQ	control box	EKEQDCB(A)/FCB/MCB(A)	0	0	0	0	0

			(1) compatibility to be investigated				
Controllers	Type Controller	Option	BRC1H51*	BRC1H519W/KS	BRC1H81W/K	BRC1H519 W7,K7,S7	BRC1H81 W7,S7
		RC for Sky Air & VRV	BRC1E53A/B/C	x	x	x	x
	wired RC for Sky Air & VRV	BRC1D52	x	x	x	x	x
	Simplified RC for hotel applications	BRC2(3)E52A	x	x	x	x	x
	VAM wired RC	BRC301B61	x	x	x	x	x
	Daikin Online Controller	BRP069A81	✓	✓	✓	✓	✓
	Centralised remote control	DCS302C51	✓	✓	✓	✓	✓
	Schedule timer	DST301B51	✓	✓	✓	✓	✓
	Unified ON/OFF control	DCS301B51	✓	✓	✓	✓	✓
	Intelligent touch controller	DCS601C51	✓	✓	✓	✓	✓
	Intelligent tablet controller	DCC601A51	✓	✓	✓	✓	✓
	Intelligent touch manager	DCM601A51	✓	✓	✓	✓	✓
standard protocol interfaces	KNX Interface	KLIC - DI	(1)	(1)	(1)	(1)	(1)
	Modbus interface	RTD-10/20/NET/HO	(1)	(1)	(1)	(1)	(1)
	LonWorks interface	EKMBOXA	✓	✓	✓	✓	✓
	BACnet interface	DMS504B51	✓	✓	✓	✓	✓
adapter PCB's		DMS502A51	✓	✓	✓	✓	✓
		KRP2A5*/KRP4A5*	✓	✓	✓	✓	✓
		DTA104A*	✓	✓	✓	✓	✓
		DTA103A51	✓	✓	✓	✓	✓
		DTA113B51	✓	✓	✓	✓	✓
	Basic solution for control of Sky Air & VRV		✓	✓	✓	✓	✓
	Key card & window contact adapter	BRP7A51/52/53/54 (ESK BE13-542_B)	✓	✓	✓	✓	✓
	Digital input adapter (P1-P2 for interlock function)	(51/52/53/54 depending on unit model)	✓	✓	✓	✓	✓
	Updater tool (PC program - ESK BE13-540_A) via PC cable	EKPCAB3 (ESK BE13-540_A)	✓	✓	✓	✓	✓

Note: for future product launches, refer to the respective data book of the new product or controller.

3. System layout

3.1 Typical layout

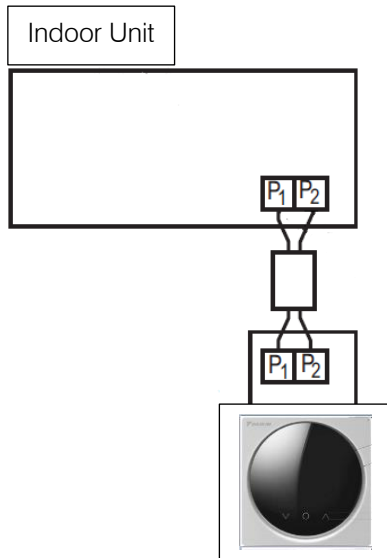

3.2 Typical layout for group control

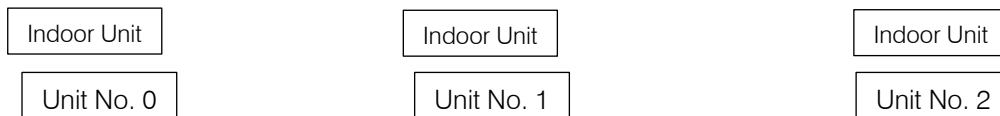

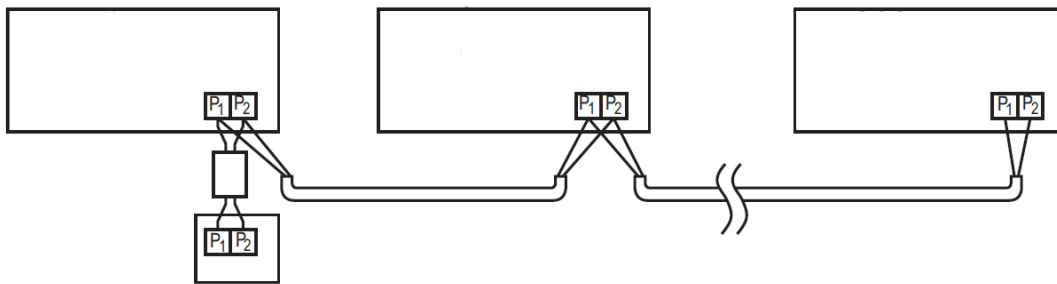

Note:

- Group control is required to be able to activate Duty Rotation & Backup.
- When using group control every unit is configured automatically with Unit No. (or address). This number determines the rotation order.
To modify this number, contact your local dealer

3.2 Typical layout for group control (with optional sub UI or Digital Input Adapter board)

3.2.1 Main/Sub UI

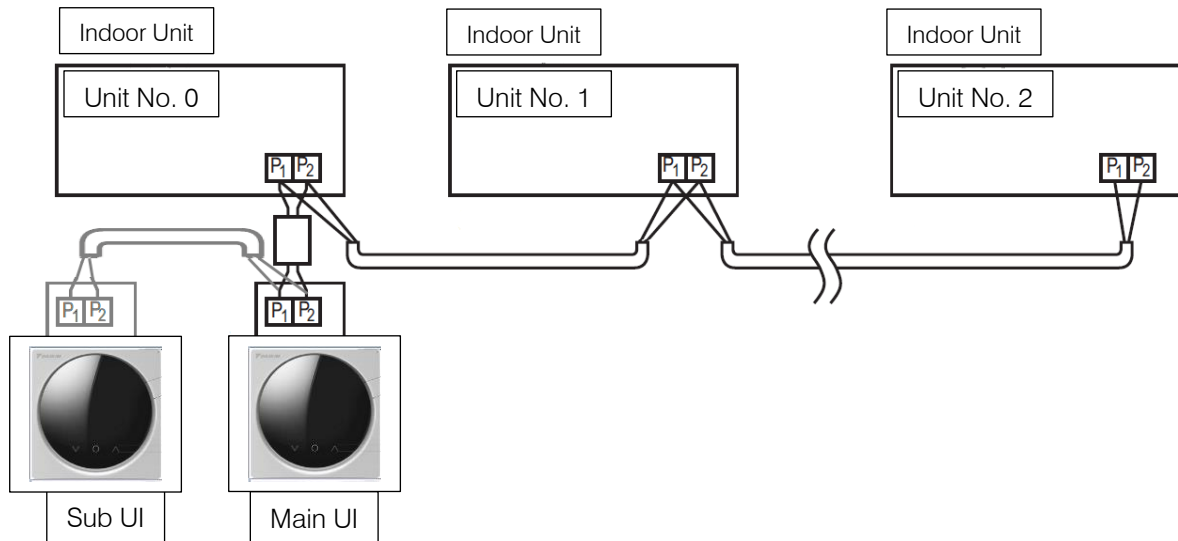

3.2.2 Digital Input Adapter board

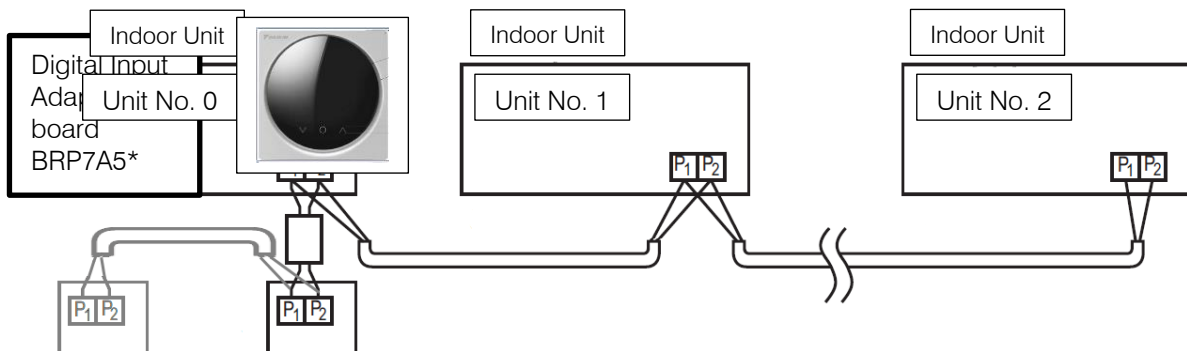

4. Specifications

4.1 Technical specifications

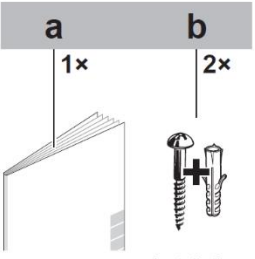
BRC1H52/82			
Content			
 <p>a 1x b 2x</p> <p>a Installation and operation manual b Wood screws + wall plugs (Ø4.0x30)</p>			
Dimensions	packing	h x w x d (mm)	50 x 217 x 161
	User interface	h x w x d (mm)	85 x 85 x 25
Weight of user interface	net weight	g	110
	gross weight	g	317
Weight of packing	material	g	Cardboard
	weight	g	85
Ambient temperature	operation	°C	-10 ~ + 50 (indoor use)
	storage	°C	-20 ~ + 70
Humidity			Below 95%RH
Colors			White (BRC1H*2W) /Black (BRC1H*2K) /Silver (BRC1H*2S)
Button cover			No
Operation lamp			BLUE STATUS INDICATOR
LCD size			40,7 x 28,0 mm
LCD type			100 x 150 Dots
Back light			Yes (white color)
Backup for power failure			yes (The clock will keep functioning for period not exceeding 48 hours)
P1P2 Connection	Wire type		Sheathed vinyl cord or cable
	Wire max. length	m	500
	No. of conductors		2
	Wire size	mm ²	0,75 – 1,25

4.2 Available documentation

Document	Contains ...	Format
Installation and operation manual	Installation and operation instructions	Paper (in the box)
Installer and user reference guide	Preparation of installation, technical specifications, reference data, ... Detailed step-by-step instructions and background information for basic and advanced usage	Digital files on: http://www.daikineurope.com/support-and-manuals/product-information

4.3 Outlook and dimensions

4.3.1 Outlook



4.3.2 Dimensions

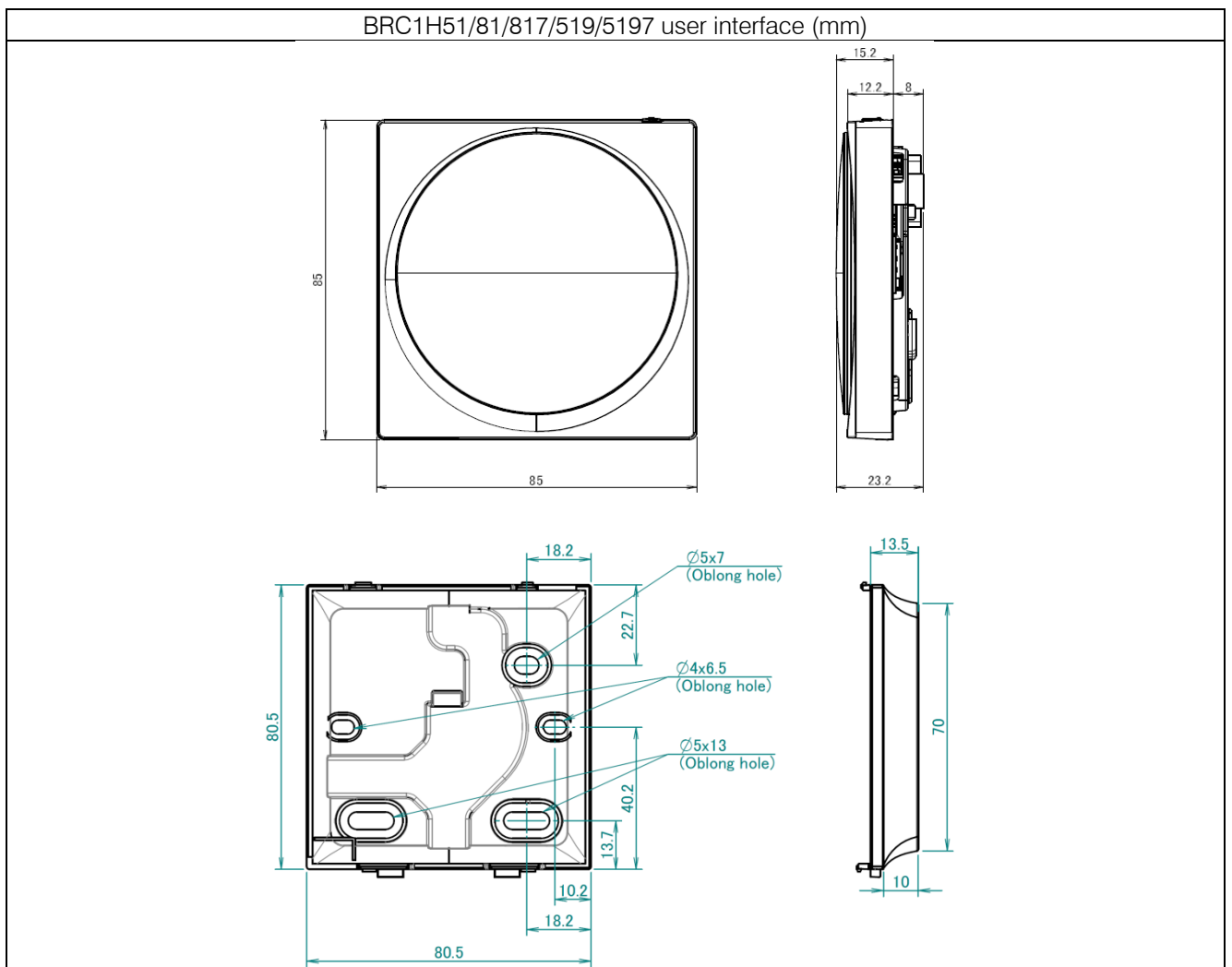

4.4 Installation method

To connect the electrical wiring:

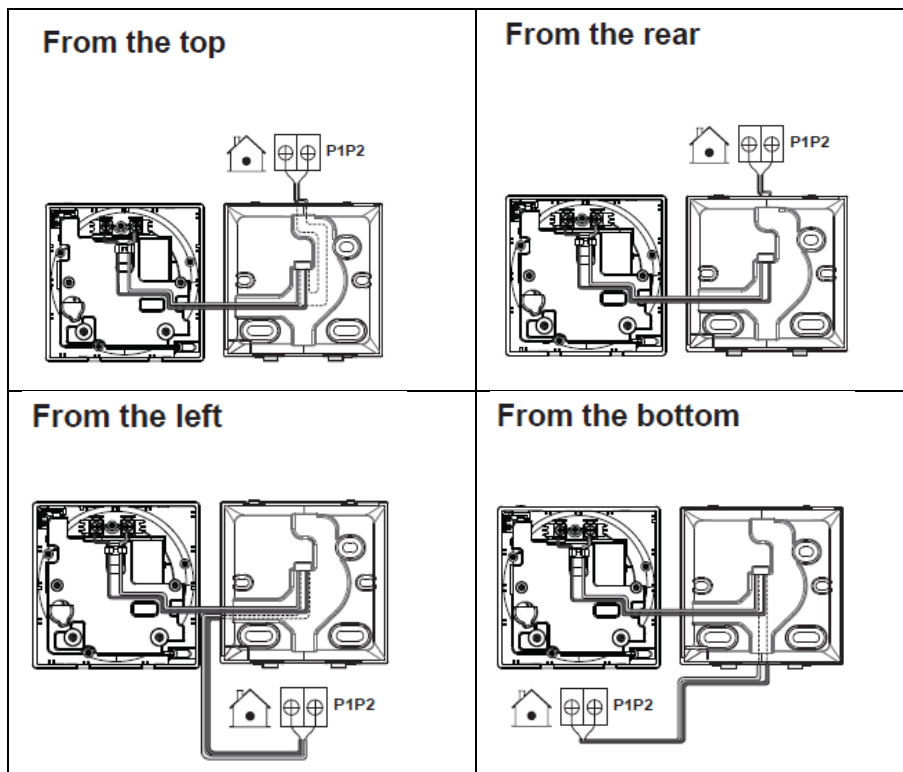

To mount the controller:

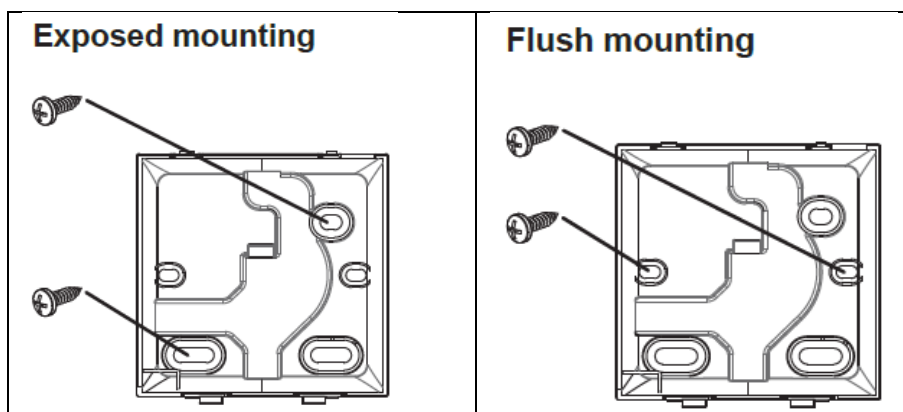

Easy Installation



2 Pre-fitted openings:

- Easy R/C opening
- No risk of



5 Summary of features

5.1 Basic user interface

The user interface is symbol driven (no text).

The basic user interface functions are:

- On/off
- Operation mode change-over:
 - Cooling / Heating or auto C/H change-over mode or fan only or dry mode
 - (auto C/H change-over mode: cooling and heating adjustable temperature settings)
- Temperature adjustment (°C) during ON/OFF operation
- Airflow level (Fan speed) adjustment
- Airflow direction (Louvre/swing) adjustment
- Filter sign and reset
- Warnings and Errors



5.2 Basic operation settings

Direct buttons for:

- On/off button at the top of the remote
- "O" Enter/Activate/Set
 - From the home screen, enter the main menu
 - From the main menu, enter one of the submenus
 - From their respective submenu, activate a function
 - In one of the submenus, confirm a setting
- "-" Cycle/ Adjust:
 - Cycle left
 - Adjust a setting (decrease)
- "+" Cycle/Adjust
 - Cycle right:
 - Adjust a setting (increase)

Others settings selectable via menu (by default accessible)

Display Selection (Simplified/detailed display mode)

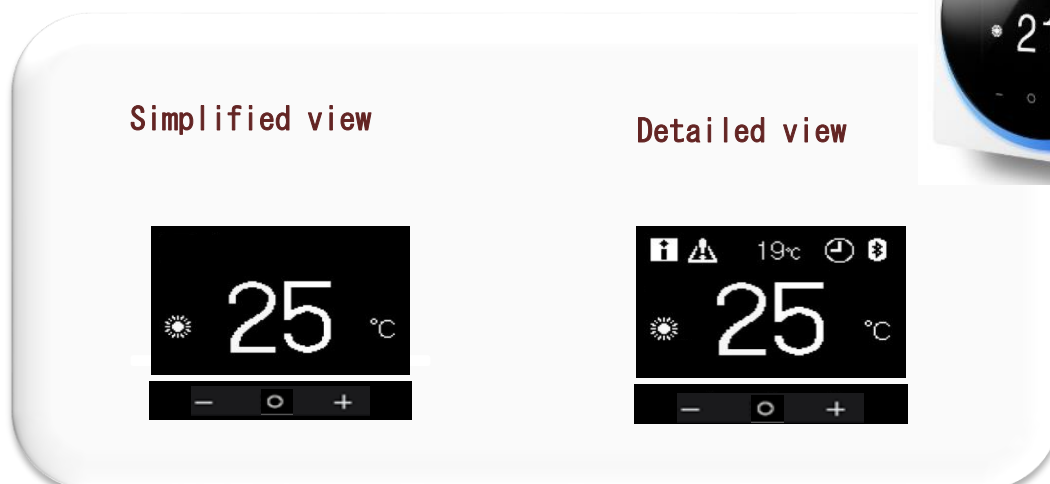

5.3 R/C Interface Logic

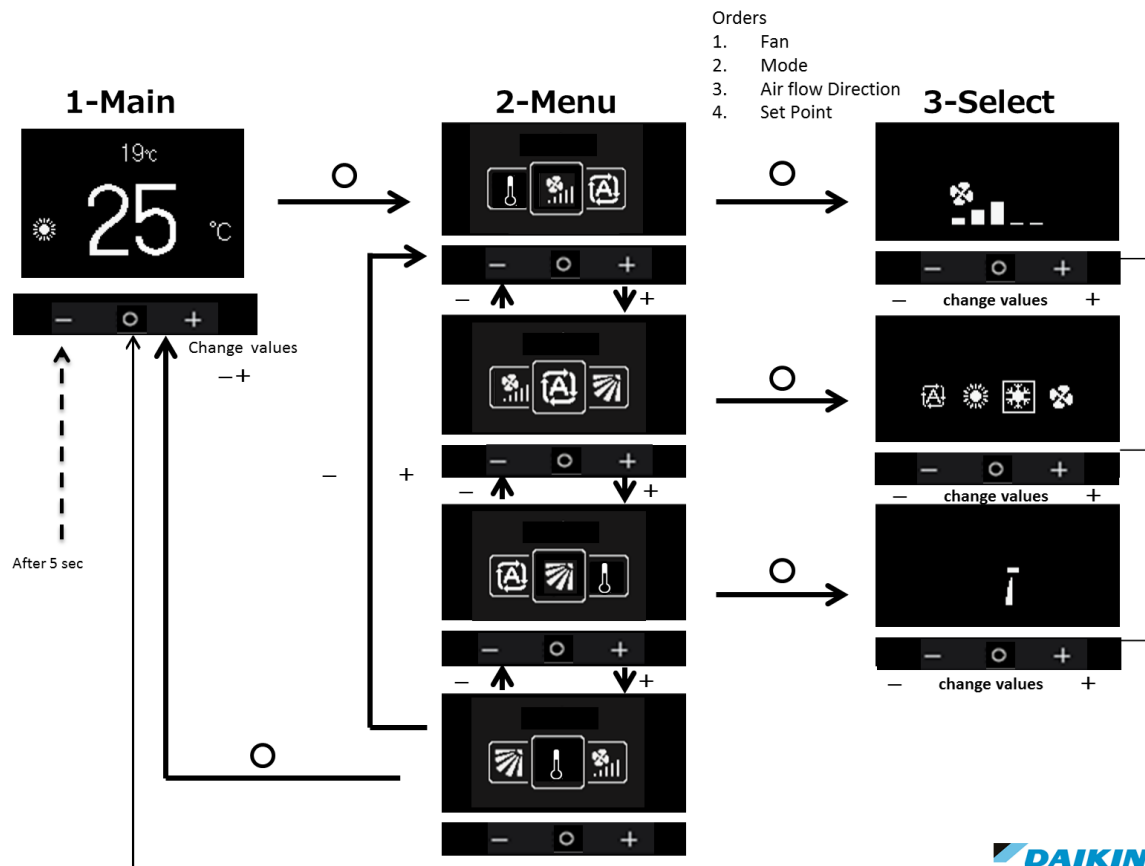

5.4 Status and operation mode icons

5.4.1 Status icons

Icon	Description	Icon	Description
	Bluetooth. ¹ Indicates that the controller is communicating with a mobile device, for use with the Daikin Control Assistant app.		Test operation. Indicates that Test Operation mode is active (Sky Air only).
	Centralised control. Indicates that the system is controlled by central control equipment (optional accessory) and control of the system by this controller is NOT possible.		Inspection. Indicates that the indoor or outdoor unit is being inspected.
	Changeover under centralised control. Indicates that the cooling/heating changeover is under centralised control by another indoor unit, or by an optional cool/ heat selector that is connected to the outdoor unit.		Periodic inspection. Indicates that the indoor or outdoor unit is being inspected.
	Defrost/Hot start. Indicates that the defrost/hot start mode is active.		Backup. Indicates that in the system an indoor unit is set as backup indoor unit.
	Timer. Indicates that the schedule timer or OFF timer is enabled.		Individual air direction. Indicates that the individual air direction setting is enabled.
	Clock not set. Indicates that the Daikin Control Assistant app clock is not set.		Message. Indicates that the system has a message to convey. Enter the menu to see the message.
	Self-cleaning filter. Indicates self-cleaning filter operation.		Capacity restriction. Indicates that the system is running with restricted capacity.
	Quick Start. Indicates that Quick Start mode is active (Sky Air only).		End of capacity restriction. Indicates that the system is no longer running with restricted capacity.
			Rotation. Indicates that Rotation mode is active.
			Setback. Indicates that the indoor unit is operating under setback control.
			Ventilation. Indicates that the unit is ventilating the space.

5.4.2 Operation mode icons

Icon	Operation mode
	Cooling. In this mode, cooling will be activated as required by the setpoint or limit operation.
	Heating. In this mode, heating will be activated as required by the setpoint or setback operation.
	Fan Only. In this mode, air circulates without heating or cooling.
	Dry. In this mode, the air humidity will be lowered with a minimal temperature decrease. The temperature and airflow level are controlled automatically and cannot be controlled by the controller. Dry operation will not function if the room temperature is too low.
	Ventilation. In this mode, the space gets ventilated, but not cooled or heated.
	Air Clean. In this mode, the optional air cleaning unit operates.
	Ventilation + Air Clean. Combination of ventilation and air clean operation.
	Auto. In Auto mode, the indoor unit automatically switches between heating and cooling mode, as required by the setpoint.

5.5 Advanced operation settings to be set by App

5.5.1 App features

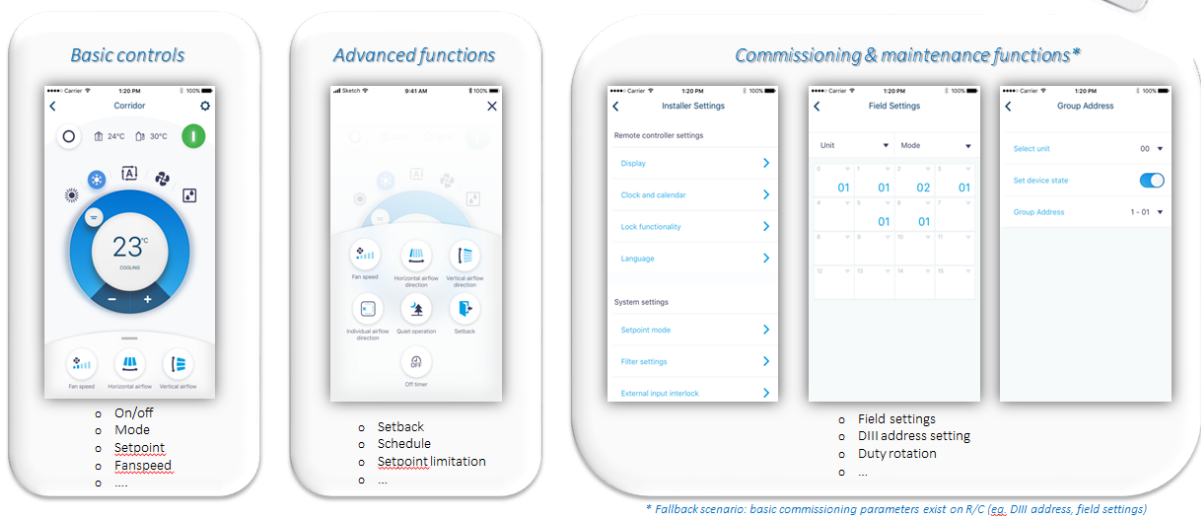

Basic controls & advanced functions: normal user

Commissioning & maintenance functions: facility manager/advance user and installers

5.5.2 Clock function

- Real time clock (display 12h or 24 h time format)
- Daylight saving time (summer/ winter time automatic change over)

5.5.3 Schedule timer function

- 3 independent schedules can be programmed: no. 1, 2 & 3
(e.g. no. 1: summer schedule, no. 2: winter schedule, no. 3: intermediate schedule)
 - A maximum of 5 actions can be programmed for each day of the week (totalling 35 actions)
 - Schedule timer no. 1, no. 2 or no. 3 can be enabled/disabled at any time (but manual selection)
 - Each action linked to a Cooling and heating set temperature or OFF (with setback or without setback) operation
 - "last command" overrules previous command until next scheduled command
- Holiday function: the schedule timer will be disabled for days that have been set as holiday

Note: Schedule timer function is disabled in case a central controller or digital input adaptor board is installed.

5.5.4 Energy Saving features

- Setpoint range limitation: The setting temperature range can be restricted (between 16 – 32°C)
Separate range limitation in cooling mode, heating mode

For BRC1H82 minimum setpoint is limited to 20°C for UAE as this is ESMA regulation.



- The setback feature will maintain the room temperature in a specific range during unoccupied periods.
Setback temperature range cooling 33° C till 37 °C, heating 10 °C till 15°C.
Setback is by default enabled.
Setback is possible when unit is switched off and setback is enabled.
Setback is applicable during heating & cooling by default or during heating only or during cooling only.
Setback setpoints can be changed when unit is switched off. Setback setpoints are shown in smaller digits.

Note: Setback should not be enabled when a central controller is connected.

- Presence sensor (if supported by the indoor unit and if present in the decoration panel(option))
Sensing energy save: setting temperature is automatically reduced (in heating) or increased (in cooling) when no people are detected during certain period.
Sensing stop set: turn off the unit when no people are detected during long period of time.
- Setting temperature auto reset:

Even if the setting temperature is changed, it returns to the pre-set temperature after a certain period

- Off timer: After you turn on the unit, it will automatically turn off after a certain period.
- Auto Display Off: When the system is switched off the blue status indicator is out
- Electricity consumption (only in case function is available on indoor unit):
(not available for indoor units connected in group control)
Indicative electricity consumption is graphical displayed
different screens: daily, weekly, monthly, yearly

5.5.5 Button lock

- Implementation only for mid July release. Behaviour not yet clear.

5.5.6 Maintenance information

When the filter is dirty, the system is in error, or the indoor unit needs to be maintained otherwise you press the menu button and see an error or maintenance screen upon trying to enter the main menu. Contact your dealer and inform him the shown error code or symbol to resolve the issue.

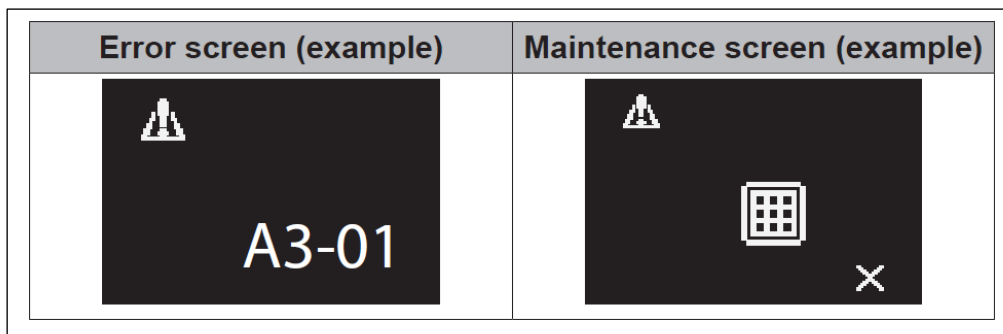

5.5.7 Quiet Mode & Demand Control

Remark: When the Quiet Mode or Demand Control mode is active the cooling or heating capacity of the system is reduced.

Quiet Mode:

A schedule can be made so that the Outdoor Unit produces less noise. If the outdoor unit supports this function then it is visible under Main menu \ Configuration.

Demand Control:

A schedule can be made so that the Outdoor Unit limits its energy consumption to 70 or 40% of the maximum energy consumption. If the outdoor unit supports this function then it is visible under Service Settings \ Demand.

5.5.8 Duty Rotation and Backup

This function is available if more than one unit is connected on the P1P2 connection (group control) of the user interface and if all these units support this function. This function is called 'Rotation' and is part of the main menu as a hidden menu item (push 4 seconds on the menu button to make it visible).

The Rotation function is designed for units operating in critical applications (e.g. in server rooms that require lots of cooling). In this case, the system is equipped with an extra backup unit. Enabling Rotation then allows for:

- Rotation: because the system is equipped with more units than are required to provide the heating/cooling load, one of the units will remain inactive during normal operation. After a set time (i.e. "Rotation cycle time", default 24h), the inactive unit will start operating and a previously active unit will become inactive (i.e. duty rotation). Because the units are alternately allowed to take a break, the lifespan of the system increases.
- Backup: having a backup unit allows for additional system redundancy. If an active unit goes into error, Rotation makes sure the inactive one takes over.
- To let the backup unit reach its cooling/heating capacity, an overlap period is included in which all units are active. (default 10min, configurable through field setting to 5', 10', 15' or 30')
 - If during the overlap period the cooling capacity is too high decrease the overlap time.
 - If after the overlap period the cooling capacity is too low increase the overlap time.
- The rotation order depends on the set Unit Number
- The indoor units need to be connected on one P1P2 connection to the user interface (group control)

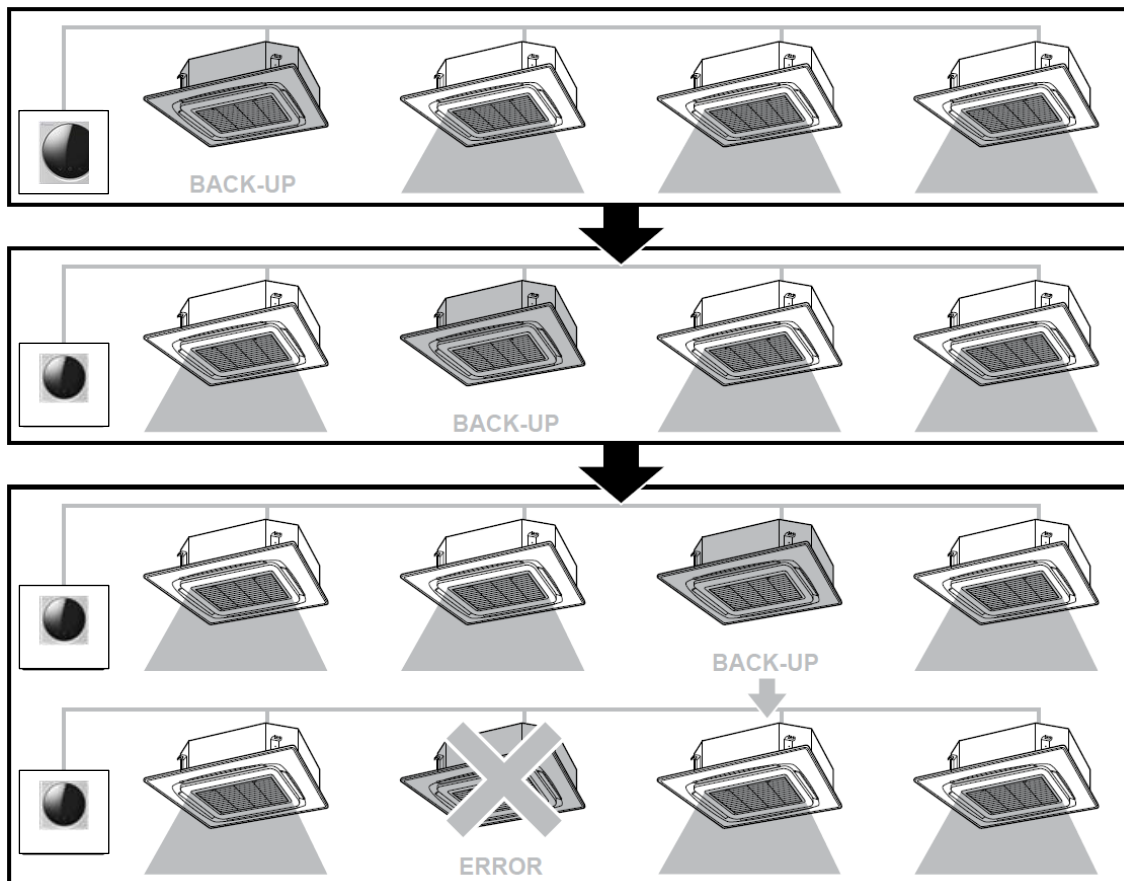

Large systems:

If the number of indoor units is too high (e.g. > 4) it is advised to create 2 (or more) groups of indoor units. Each group will then be under control of one UI and have one back-up unit. Each group will work *independently* and will have its own rotation cycle, overlap time and back-up unit.

This table shows –as a rule of thumb– the amount of units per group:

No. of indoor units	No. of groups	No. of Remocon	No. of Back-up Units
1 – 4	1	1	1
5 – 8	2	2	2
9 – 12	3	3	3
13 - 16	4	4	4

5.6 Options

5.6.1 Digital Input Adapter Board (BRP7A51/52/53/54)

Interlock with 2 external signals B1 & B2 (only in combination with BRP7A5* digital input adapter)
 Remark: only a dry contact contact can be connected: Normally open or Normally closed.

Typical application: Offices or hotels interlock with field-supplied window contact B1

Remark:

- The interlock feature is explained in installer Reference Guide
- In case Interlock with external signals is installed, schedule timer function is disabled
- The digital input adapter needs to be connected to the P1P2 connection. In this case no sub User Interface can be connected.
- Depending on the indoor unit it might be required to use an installation box, mounting plate or casing (e.g. option KRP1BA101, KRP1H98,...) to mount the digital input adapter board.

5.6.2 Software Updater

With the 'PC USB cable' option EKPCAB4 + updater software
 Upgrade current model
 Upload new software in case of issues

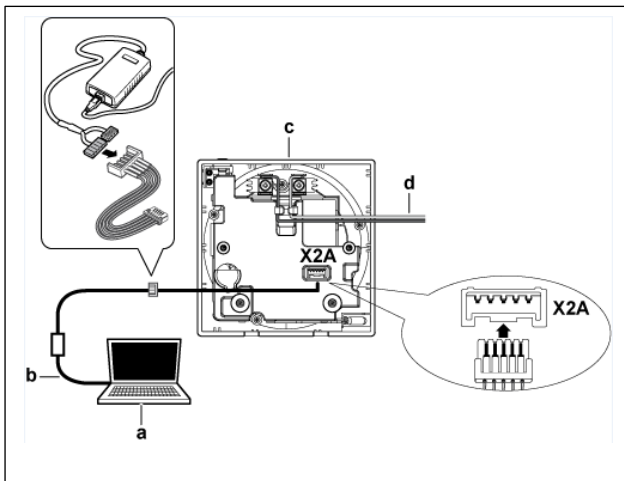

By entering model name possible updates are displayed.

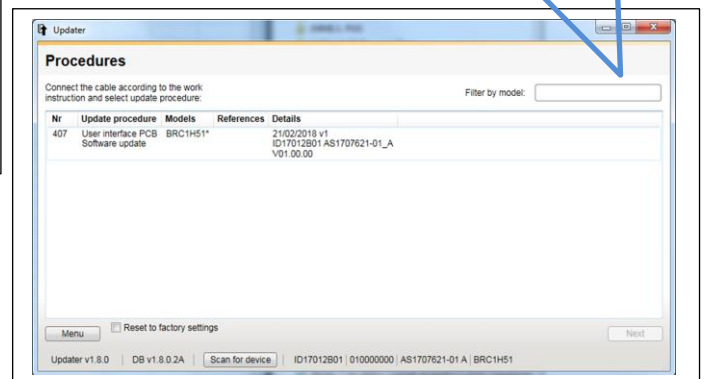

5.7 Smartphone requirements, pairing, connection & features

5.7.1 Apple iOS 8.0 or higher



Typical models are iPhone 4s and later, iPad 2 and later, all iPad minis and iPod Touch 5th generation and later

5.7.2 Android 5.0 or higher and Bluetooth Low Energy 4.2 or higher



5.7.3 Pairing

Advertising

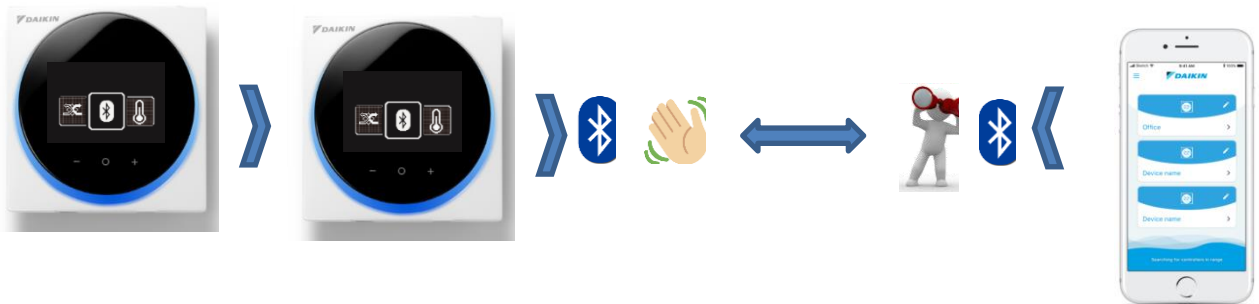

Numeric comparison: numeric value is on the R/C and the App to confirm pairing



5.7.4 App connection

Only one R/C can be connected to the App at the time
 Paired device are stored on the R/C & the App
 Up to 10 paired devices can be stored on the R/C

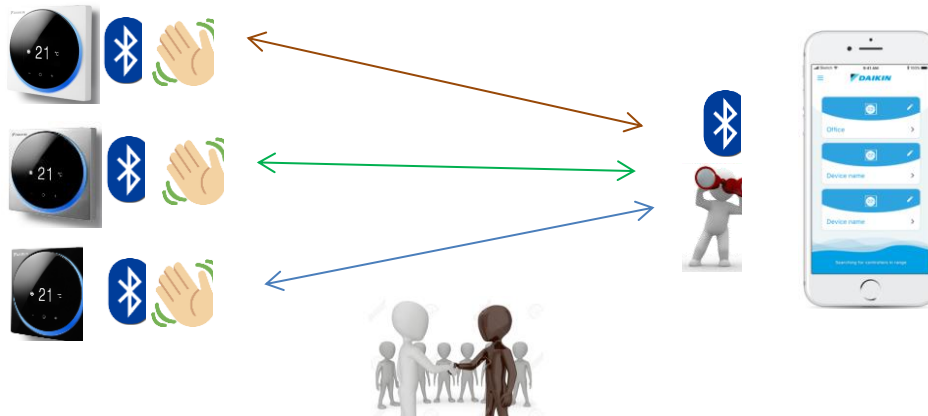

6. Combination BRC1H52/82 & DIII central control equipment

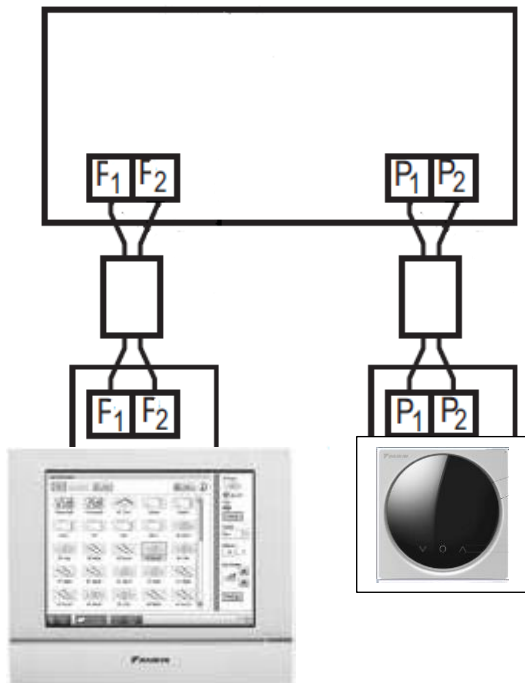

This configuration has impact on the following functions:

- Schedule timer function will be disabled on the remote controller
- Setback should not be enabled on the BRC1H (can be enabled on iTM for example)

7. Madoka R32 leak alarm

7.1 General logic

To comply with the R32 legislation the BRC1H52/82 has been equipped with a buzzer functionality.

Trough field settings three configurations are possible



R/C + alarm

Applications requiring R/C



Alarm

Applications not requiring R/C → Alarm only



Supervisor

Supervisor R/C -> alarm + visible indication

Alarm function activation on:

1. R/C + Alarm:

- Automatic activation of Alarm function when leak is detected. Based on the auto detection of the connected system type (R32/R410A), the Alarm functions are available or masked
- Indication is available on the information page of the app when connected to R32 system.
- Alarm function are manageable from R/C & APP (see 7.2 R/C logic)

2. Alarm:

- Automatic activation of Alarm function when leak is detected. Based on auto detection of the connected system type (R32/R410A), the Alarm functions are available or masked
- Indication is available on the information page of the app when connected to R32 system.
- if Madoka PCB is used, alarm function are manageable from R/C hardware & APP (see 7.2 R/C logic)

3. Supervisor R/C:

- In this case Madoka is used as central alarm for e.g. a lobby in a motel
- There is a visible and audible alarm
 - Info on the alarm origin. Which indoor unit has the leakage alarm
 - Other errors, not related on the leakage alarm, can also be shown on this supervisor R/C
 - It's NOT possible to turn of the local alarm of the indoor unit directly from supervisor R/C



What happens when a leak is detected:

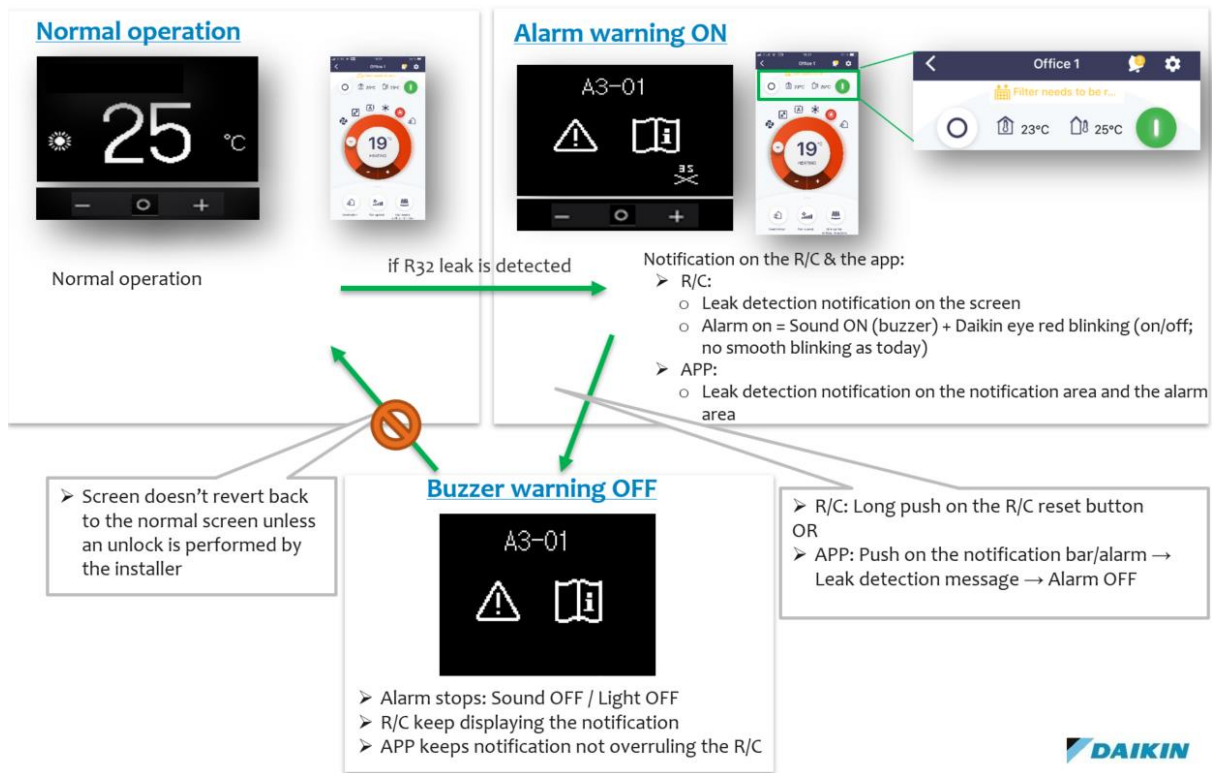

7.2 Compatibility with other controller

7.2.1 Central control connection

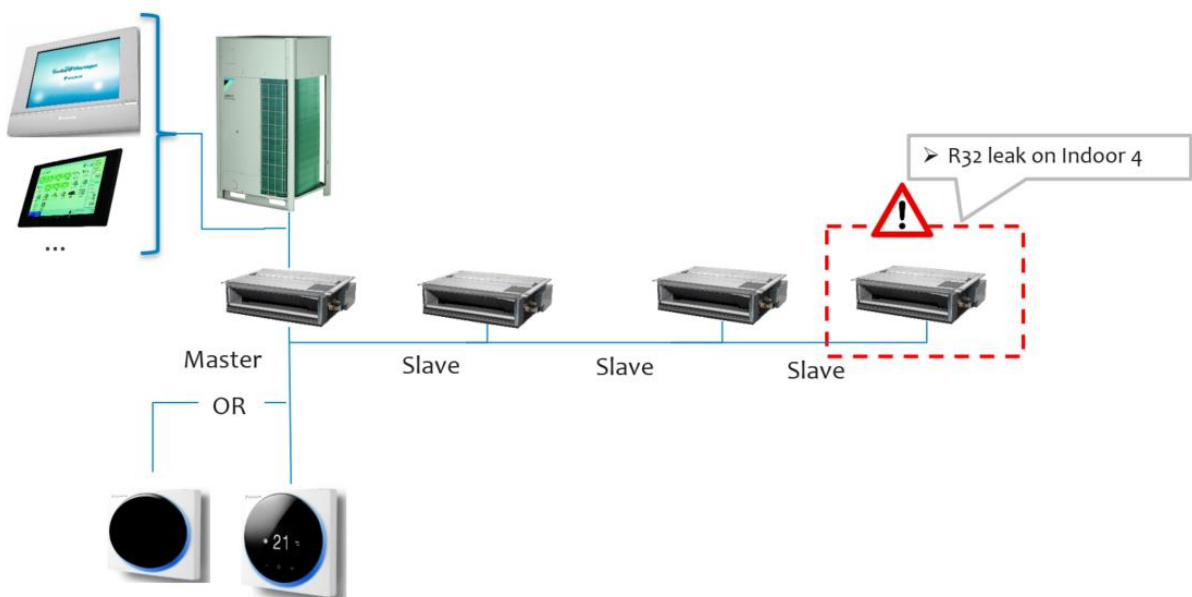

7.2.2 Slave controller/gateways combination

Gateways as KNX/RTD's/KRP are compatible with BRC1H52/82 but only in "Slave" combination

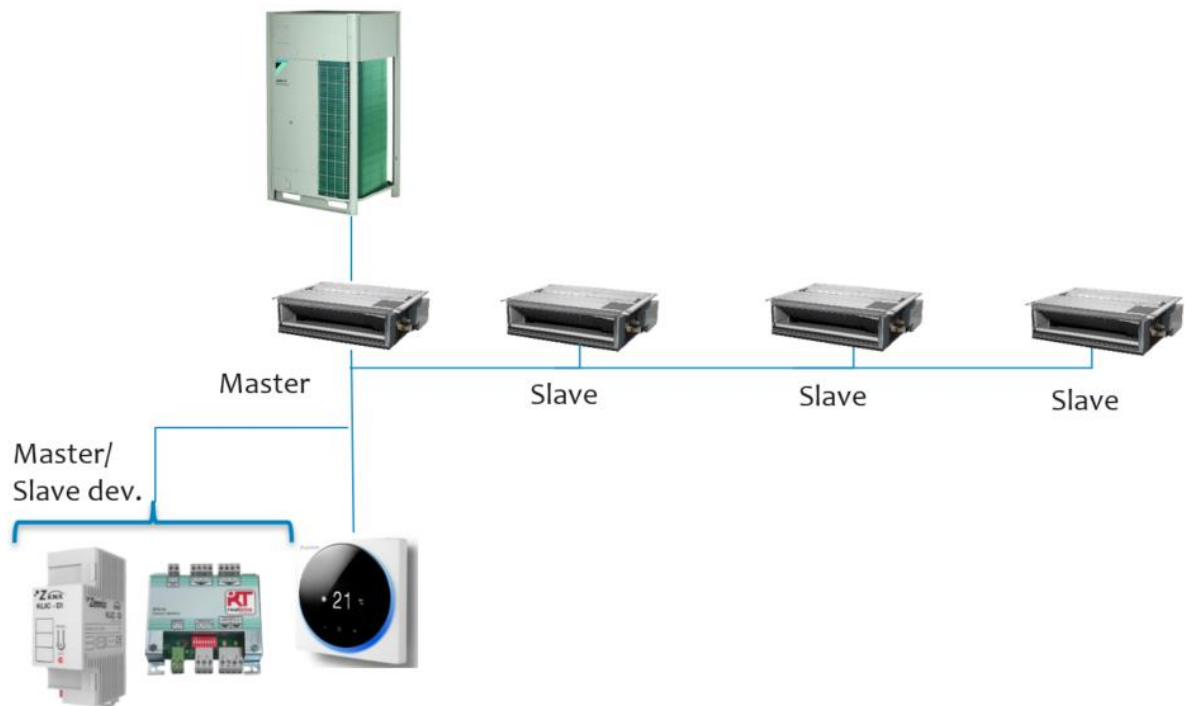

7.2.3 Wireless R/C combination

The wireless controller is compatible with the R32 system as "Slave" device

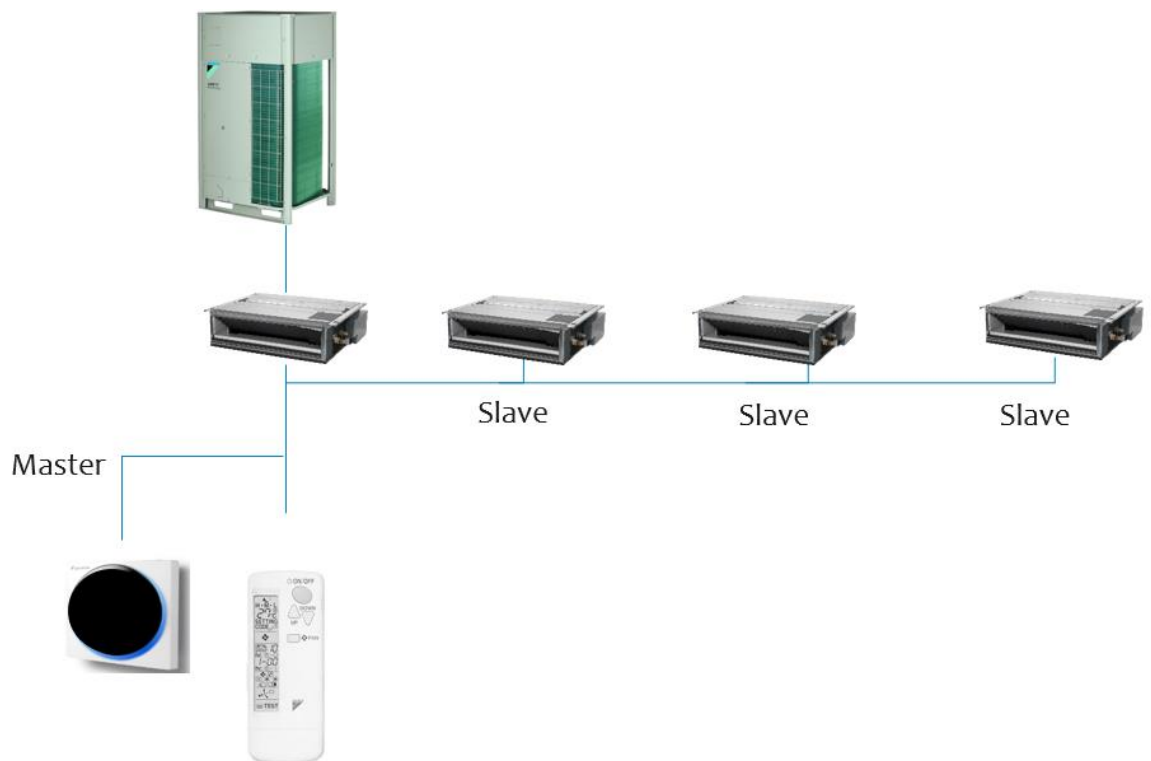

8. Revision

27/11/2019	D. De Smeyter	Rev 0.1 Draft based on BRC1H51/81/81*7/519/519*7 datasheet
28/11/2019	D. De Smeyter	Rev 1.0 first release