



Sky Air Alpha-series
Air Conditioning
Technical Data
RZAG-NY1



TABLE OF CONTENTS

RZAG-NY1

1	Features	4
	RZAG-NY1	4
2	Specifications	5
3	Electrical data	17
4	Options	20
5	Combination table	21
6	Capacity tables	22
	Cooling/Heating Capacity Tables	23
	Capacity Correction Factor	26
7	Dimensional drawings	27
8	Centre of gravity	28
9	Piping diagrams	29
	Piping Diagram Twin Application	30
	Piping Diagram Triple Application	31
	Piping Diagram Double Twin Application	31
10	Wiring diagrams	33
	Wiring Diagrams - Single Phase	33
11	Sound data	34
	Sound Power Spectrum	34
	Sound Pressure Spectrum - Cooling	36
	Sound Pressure Spectrum - Heating	38
	Sound Pressure Spectrum Quiet Mode Level 1	40
	Sound Pressure Spectrum Quiet Mode Level 2	42
	Sound Pressure Spectrum Quiet Mode Level 3	44
12	Installation	46
	Installation Method	47
13	Operation range	49
14	Appropriate Indoors	50

1 Features

1 - 1 RZAG-NY1

Industry leading technology in the most compact casing ever

- › Unique, low-height single fan range
- › Compact dimensions allow almost unnoticeable installation
- › Market-leading serviceability and handling, thanks to wide access area, 7-segment display and additional handle
- › Top efficiency: - Energy labels up to A++ in both cooling and heating - compressor offers substantial efficiency improvements
- › Choosing for an R-32 product, reduces the environmental impact with 68% compared to R-410A, leads directly to lower energy consumption thanks to its high energy efficiency and has a lower refrigerant charge
- › The perfect balance in efficiency and comfort thanks to Variable Refrigerant Temperature: top seasonal efficiency throughout most of the year and quick reaction speed on the hottest days.
- › Suits high sensible, infrastructure cooling applications
- › Replace existing systems with R-32 technology without needing to replace the piping
- › Guarantees operation in both heating and cooling mode down to -20°C
- › Refrigerant cooled PCB guarantees reliable cooling, as it is not influenced by ambient temperature.
- › Maximum piping length up to 85m
- › Outdoor units for pair, twin, triple, double twin application



Infrastructure cooling (optional)



Guaranteed operation down to -20°C



Seasonal efficiency - Smart use of energy



Inverter (optional)



Swing compressor



Replacement technology



Auto cooling-heating changeover (optional)



Night quiet mode (optional)



Twin/triple/double twin application



Variable refrigerant temperature



Low sound enclosure (optional)

2 Specifications

2 - 1 Specifications

Technical Specifications					RZAG71NY1	RZAG100NY1	RZAG125NY1	RZAG140NY1	
Casing	Colour	Ivory white							
	Material	Painted galvanized steel plate							
Dimensions	Unit	Height	mm	870					
		Width	mm	1,100					
		Depth	mm	460					
	Packed unit	Height	mm	1,050					
		Width	mm	1,205					
		Depth	mm	569					
Weight	Unit	kg	81	85	94				
	Packed unit	kg	92	96	105				
Packing	Weight	kg	10						
Heat exchanger	Fin	WF fin							
	Type Treatment	Anti-corrosion treatment (PE)							
Fan	Type	Propeller							
	Discharge direction	Horizontal							
	Quantity	1							
	Air flow rate	Cooling	Nom.	m ³ /min	68	67	80	87	
Heating			Nom.	m ³ /min	75	82	80	87	
		Partial	m ³ /min	-		45 (1)			
Fan motor	Quantity	1							
	Model	Brushless DC motor							
	Output	W	234						
	Drive	Direct drive							
Compressor	Quantity	1							
	Type	Hermetically sealed swing compressor							
Refrigerant	Charge	tCO ₂ Eq	2.16	2.50					
Operation range	Cooling	Ambient	Min.	°CDB	-20				
			Max.	°CDB	52				
	Heating	Ambient	Min.	°CWB	-20				
			Max.	°CWB	18				
Sound power level	Cooling		dBA	64	66	69	70		
	Heating		dBA	-		68 (1)	71 (1)		
Sound pressure level	Cooling	Nom.	dBA	46	47	49	50		
	Heating	Nom.	dBA	48	50	52			
Refrigerant	Type	R-32							
	Charge	kg	3.20	3.70					
Refrigerant	Control	Expansion valve (electronic type)							
	GWP	675							
	Circuits	Quantity	1						
Refrigerant oil	Type	FW68DA							
	Charged volume	l	0.9	1.4					
Piping connections	Liquid	Quantity	1						
		Type	Flare connection						
		OD	mm	10					
	Gas	Quantity	1						
		Type	Flare connection						
		OD	mm	15.9					
	Drain	Quantity	8						
		Type	Hole						
		OD	mm	26					
	Piping length	OU - IU	Min.	m	3				
			Max.	m	55	85			
		System	Equivalent	m	75	100			
			Chargeless	m	40				
		Additional refrigerant charge	kg/m	See installation manual					
		Level difference	IU - OU	Max.	m	30			
			IU - IU		m	0.5			
	Heat insulation	Both liquid and gas pipes							
Defrost method	Reversed cycle								
Defrost control	Sensor for outdoor heat exchanger temperature								
Capacity control	Method	Inverter controlled							
PED	Category	Category II							
	Most critical part	Name	Accumulator						
		Ps*V	Bar*l	136.5	143.0				
Safety devices	Item	01	High pressure switch						
		02	Low pressure switch						
		03	Fan driver overload protector						
		04	Fuse						
		05	Compressor motor thermal protector						

Standard accessories: Tie-wraps;Quantity: 2;

Standard accessories: Installation manual;Quantity: 1;

Standard accessories: General safety precautions;Quantity: 1;

2 Specifications

2 - 1 Specifications

Standard accessories: Peel off F-gas label;Quantity: 1;

Standard accessories: Refrigerant label for F-gas regulation;Quantity: 1;

2

Electrical Specifications			RZAG71NY1	RZAG100NY1	RZAG125NY1	RZAG140NY1
Power supply	Name					Y1
	Phase					3~
	Frequency	Hz				50
	Voltage	V				380-415
	Voltage range	V				342 457
Current	Zmax	List	Complies to EN61000-3-11			
Wiring connections	For power supply	Remark	See installation manual outdoor unit			
	For connection with indoor	Remark	See installation manual outdoor unit			
Power supply intake			See installation manual outdoor unit			
Current - 50Hz	Maximum fuse amps (MFA)	A	16			

(1)According to ENER Lot 21

Technical specifications			FCAHG71H + RZAG71NY1	FCAHG100H + RZAG71NY1	FCAHG100H + RZAG100NY1	FCAHG140H + RZAG100NY1	FCAHG125H + RZAG125NY1	FCAHG140H + RZAG140NY1	
Cooling capacity	Nom.	kW	6.80 (1)		9.50 (1)		12.1 (1)	13.4 (1)	
Heating capacity	Nom.	kW	7.50 (2)		10.8 (2)		13.5 (2)	15.5 (2)	
Space cooling	Energy efficiency class		A++				-		
	Capacity	Pdesign	6.80		9.50		12.1	13.4	
	SEER		7.90	7.05	7.70	7.49	8.02	7.93	
	ηs,c	%	-				318	314	
	Annual energy consumption	kWh/a	301	338	432	444	905	1,014	
Space heating (Average climate)	Energy efficiency class		A+		A++		-		
	Capacity	Pdesign	4.70		9.52				
	SCOP/A		4.56	4.20	4.75	4.70	4.53	4.44	
	SCOPnet/A		4.56	4.20	4.75	4.70	4.53	4.44	
	ηs,h	%	-				178	175	
Annual energy consumption	kWh/a	1,443	1,567	2,805	2,836	2,943	3,002		
Required back up heating cap at design conditions	kW	0.00							
Space cooling	A Condition	Pdc	6.80		9.50		12.10	13.40	
	(35°C - 27/19)	EERd	4.13	4.14	4.23	4.04	3.84	3.68	
		Power input	1.65	1.64	2.25	2.35	3.15	3.64	
	B Condition	Pdc	5.01	5.03	7.00	7.03	8.92	9.88	
	(30°C - 27/19)	EERd	5.96	6.00	6.14	5.96	5.81	5.77	
		Power input	0.84		1.14	1.18	1.54	1.71	
	C Condition	Pdc	3.22	3.20	4.50	4.46	5.74	6.35	
	(25°C - 27/19)	EERd	10.19	8.66	9.32	9.12	9.63	9.37	
		Power input	0.32	0.37	0.48	0.49	0.60	0.68	
	D Condition	Pdc	2.64	2.72	3.71	3.59	3.61		
	(20°C - 27/19)	EERd	14.60	10.83	12.87	12.38	13.99	14.07	
		Power input	0.18	0.25	0.29		0.26		
	Space heating (Average climate)	TOL	Tol (temperature operating limit)	°C				-10	
		Pdh (declared heating cap)	4.70		9.52				
		COPd (declared COP)	2.91	2.94	2.79	2.77	2.22	2.23	
		Power input	1.62	1.60	3.42	3.43	4.29	4.27	
TBivalent		Tbiv (bivalent temperature)	°C				-10		
		Pdh (declared heating cap)	4.70		9.52				
		COPd (declared COP)	2.91	2.94	2.79	2.77	2.22	2.23	
		Power input	1.62	1.60	3.42	3.43	4.29	4.27	
A Condition		Pdh (declared heating cap)	4.16	4.14	8.42	8.38	8.42		
(-7°C)		COPd (declared COP)	3.28	3.30	3.14	3.13	2.84	2.80	
Space heating (Average climate)		A Condition	Power input	1.27	1.25	2.69	2.68	2.97	3.01
		(-7°C)							
		B Condition	Pdh (declared heating cap)	2.53	2.54	5.13	5.14	5.13	
	(2°C)	COPd (declared COP)	4.53	4.30	4.79	4.76	4.58	4.42	
		Power input	0.56	0.59	1.07	1.08	1.12	1.16	
	C Condition	Pdh (declared heating cap)	1.79	1.89	3.30	3.33	3.30		
	(7°C)	COPd (declared COP)	5.43	4.73	5.81	5.71	5.79	5.78	
		Power input	0.33	0.40	0.57	0.58	0.57		
	D Condition	Pdh (declared heating cap)	2.01	2.11	2.58	2.60			
	(12°C)	COPd (declared COP)	6.79	5.75	6.86	6.64	6.62	6.60	
	Power input	0.30	0.37	0.38	0.39				

2 Specifications

2 - 1 Specifications

Technical specifications					FCAHG71H + RZAG71NY1	FCAHG100H + RZAG71NY1	FCAHG100H + RZAG100NY1	FCAHG140H + RZAG100NY1	FCAHG125H + RZAG125NY1	FCAHG140H + RZAG140NY1	
Power consumption in other than active mode	Crankcase heater mode	Cooling	PCK	kW						0.000	
		Heating	PCK	kW						0.000	
	Off mode	Cooling	POFF	kW						0.009	
		Heating	POFF	kW						0.009	
	Standby mode	Cooling	PSB	kW						0.009	
		Heating	PSB	kW						0.009	
	Thermo-stat-off mode	Cooling	PTO	kW						0.005	
		Heating	PTO	kW						0.013	
Indication if the heater is equipped with a supplementary heater (pair application)										No	
Supplementary heater (pair application)	Back-up capacity	Heating	elbu	kW						0.0	
Cooling	Cdc (Degradation cooling)									0.25	
Heating	Cdh (Degradation heating)									0.25	
Cooling function included										Yes	
Heating function included										Yes	
Average climate included										Yes	
Cold season included										No	
Warm season included										No	

(1)Nominal cooling capacities are based on: indoor temperature: 27°CDB, 19°CWB, outdoor temperature: 35°CDB, equivalent refrigerant piping: 5m, level difference: 0m. |

(2)Nominal heating capacities are based on: indoor temperature: 20°CDB, outdoor temperature: 7°CDB, 6°CWB, equivalent refrigerant piping: 5m, level difference: 0m.

Technical specifications					FCAG71B + RZAG71NY1	FCAG100B + RZAG71NY1	FCAG100B + RZAG100NY1	FCAG140B + RZAG100NY1	FCAG125B + RZAG125NY1	FCAG140B + RZAG140NY1
Cooling capacity	Nom.	kW	6.80 (1)		9.50 (1)			12.1 (1)	13.4 (1)	
Heating capacity	Nom.	kW	7.50 (2)		10.8 (2)			13.5 (2)	15.5 (2)	
Space cooling	Energy efficiency class		A++							
	Capacity	Pdesign	kW	6.80		9.50		12.1	13.4	
	SEER			6.83	7.50	7.14	7.86	7.15	6.80	
	ηs,c		%					283	269	
	Annual energy consumption		kWh/a	348	317	466	423	1,016	1,182	
Space heating (Average climate)	Energy efficiency class		A+							
	Capacity	Pdesign	kW	4.70		7.80		9.52		
	SCOP/A			4.22	4.45	4.53	4.66	4.34		
	SCOPnet/A			4.22	4.45	4.53	4.66	4.34		
	ηs,h		%					171		
	Annual energy consumption		kWh/a	1,560	1,479	2,413	2,343	3,071		
Required back up heating cap at design conditions										0.00
Space cooling	A Condition (35°C - 27/19)	Pdc	kW	6.80		9.50		12.10	13.40	
		EERd		3.54	4.14	3.59	4.13	3.32	3.12	
		Power input	kW	1.92	1.64	2.65	2.30	3.65	4.29	
	B Condition (30°C - 27/19)	Pdc	kW	5.03		7.03		8.92	9.88	
		EERd		5.43	5.65	5.83	5.76	5.65	4.47	
		Power input	kW	0.93	0.89	1.21	1.22	1.58	2.21	
	C Condition (25°C - 27/19)	Pdc	kW	3.20		4.46		5.74	6.35	
		EERd		8.32	9.57	8.18	9.72	7.87	8.17	
		Power input	kW	0.38	0.33	0.55	0.46	0.73	0.78	
	D Condition (20°C - 27/19)	Pdc	kW	2.40	2.65	3.31	3.61	3.25	3.32	
		EERd		12.31	13.42	13.03	14.70	12.77	13.55	
		Power input	kW	0.20		0.25				
Space heating (Average climate)	TOL	Tol (temperature operating limit)	°C	-10						
		Pdh (declared heating cap)	kW	4.70		7.80		9.52		
		COPd (declared COP)		2.54	2.88	2.51	2.73	1.91	1.93	
	Power input	kW	1.85	1.63	3.11	2.85	4.98	4.93		
	TBivalent	Tbiv (bivalent temperature)	°C	-10						
		Pdh (declared heating cap)	kW	4.70		7.80		9.52		
		COPd (declared COP)		2.54	2.88	2.51	2.73	1.91	1.93	
	Power input	kW	1.85	1.63	3.11	2.85	4.98	4.93		
	A Condition (-7°C)	Pdh (declared heating cap)	kW	4.13	4.14	6.86		8.43	8.42	
		COPd (declared COP)		2.96	3.25	2.87	3.04	2.59	2.52	

2 Specifications

2 - 1 Specifications

2

Technical specifications				FCAG71B + RZAG71NY1	FCAG100B + RZAG71NY1	FCAG100B + RZAG100NY1	FCAG140B + RZAG100NY1	FCAG125B + RZAG125NY1	FCAG140B + RZAG140NY1		
Space heating (Average climate)	A Condition (-7°C)	Power input	kW	1.40	1.27	2.39	2.26	3.25	3.34		
		Pdh (declared heating cap)	kW	2.54		4.21		5.12			
	B Condition (2°C)	COPd (declared COP)		4.23	4.46	4.37	4.65	4.29	4.33		
		Power input	kW	0.60	0.57	0.96	0.91	1.20	1.18		
	C Condition (7°C)	Pdh (declared heating cap)	kW	1.77	1.80	2.73		3.29			
		COPd (declared COP)		5.11	5.30	6.01	5.82	5.92			
		Power input	kW	0.35	0.34	0.45	0.47	0.56			
	D Condition (12°C)	Pdh (declared heating cap)	kW	1.96	2.02	2.47	2.51	2.52			
		COPd (declared COP)		6.01	6.60	7.75	7.16	6.94			
		Power input	kW	0.33	0.31	0.32	0.35	0.36			
Power consumption in other than active mode	Crankcase heater mode	Cooling PCK	kW						0.000		
		Heating PCK	kW						0.000		
	Off mode	Cooling POFF	kW						0.009		
		Heating POFF	kW						0.009		
	Standby mode	Cooling PSB	kW						0.009		
		Heating PSB	kW						0.009		
	Thermo-stat-off mode	Cooling PTO	kW						0.005		
		Heating PTO	kW						0.013		
	Indication if the heater is equipped with a supplementary heater (pair application)									No	
	Supplementary heater (pair application)	Back-up capacity	Heating elbu	kW						0.0	
Cooling Cdc (Degradation cooling)									0.25		
Heating	Cdh (Degradation heating)							0.25			
Cooling function included									Yes		
Heating function included									Yes		
Average climate included									Yes		
Cold season included									No		
Warm season included									No		

(1)Nominal cooling capacities are based on: indoor temperature: 27°CDB, 19°CWB, outdoor temperature: 35°CDB, equivalent refrigerant piping: 5m, level difference: 0m. |

(2)Nominal heating capacities are based on: indoor temperature: 20°CDB, outdoor temperature: 7°CDB, 6°CWB, equivalent refrigerant piping: 5m, level difference: 0m.

2 Specifications

2 - 1 Specifications

Technical specifications				FBA71A9 + RZAG71NY1	FBA100A + RZAG71NY1	FBA100A + RZAG100NY1	FBA140A + RZAG100NY1	FBA125A + RZAG125NY1	FBA140A + RZAG140NY1	
Cooling capacity	Nom.	kW	6.80 (1)			9.50 (1)		12.1 (1)	13.4 (1)	
Heating capacity	Nom.	kW	7.50 (2)			10.8 (2)		13.5 (2)	15.5 (2)	
Space cooling	Energy efficiency class		A++	A+	A++		-			
	Capacity	Pdesign	kW	6.80		9.50		12.1	13.4	
	SEER		6.50	5.81	6.47	6.39	6.56	6.42		
	η _{s,c}	%	-			-		259	254	
	Annual energy consumption		kWh/a	366	410	514	520	1,107	1,252	
Space heating (Average climate)	Energy efficiency class		A+			-		-		
	Capacity	Pdesign	kW	4.70		7.80		9.52		
	SCOP/A		4.20	4.06	4.36	4.20	4.37	4.34		
	SCOPnet/A		4.20	4.06	4.36	4.20	4.37	4.34		
	η _{s,h}	%	-			-		172	171	
	Annual energy consumption		kWh/a	1,566	1,621	2,505	2,600	3,050	3,070	
	Required back up heating cap at design conditions		kW	-			0.00		-	
Space cooling	A Condition (35°C - 27/19)	Pdc	kW	6.80		9.50		12.10	13.40	
		EERd		3.40	4.15	3.69	4.18	3.27	2.86	
		Power input	kW	2.00	1.64	2.58	2.27	3.70	4.69	
	B Condition (30°C - 27/19)	Pdc	kW	5.03		7.03		8.92	9.88	
		EERd		5.07	4.39	4.92	4.69	4.95	4.64	
		Power input	kW	0.99	1.15	1.43	1.50	1.80	2.13	
	C Condition (25°C - 27/19)	Pdc	kW	3.20		4.46		5.74	6.35	
		EERd		7.94	7.06	7.80	7.62	7.45	7.47	
		Power input	kW	0.40	0.45	0.57	0.59	0.77	0.85	
	D Condition (20°C - 27/19)	Pdc	kW	2.44		3.33		3.66	3.50	
		EERd		12.41	9.51	11.22	11.10	11.49	12.13	
		Power input	kW	0.20	0.28	0.30	0.33	0.29		
	Space heating (Average climate)	TOL	Tol (temperature operating limit)		°C		-10		-	
			Pd _h (declared heating cap)		kW		4.70		7.80	
COP _d (declared COP)					2.50	2.69	2.46	2.52		
Power input			kW		1.88	1.75	3.17	3.09		
TBivalent		Tbiv (bivalent temperature)		°C		-10		-		
		Pd _h (declared heating cap)		kW		4.70		7.80		
		COP _d (declared COP)				2.50	2.69	2.46	2.52	
		Power input		kW		1.88	1.75	3.17	3.09	
A Condition (-7°C)		Pd _h (declared heating cap)		kW		4.14		6.87		
		COP _d (declared COP)				2.92	3.04	2.82	2.80	
Space heating (Average climate)		A Condition (-7°C)	Power input		kW		1.42	1.36	2.43	2.45
			Pd _h (declared heating cap)		kW		2.54		4.21	
		B Condition (2°C)	COP _d (declared COP)				4.21	4.10	4.33	4.20
			Power input		kW		0.60	0.62	0.97	1.00
	Pd _h (declared heating cap)		kW		1.76	1.83	2.73			
	C Condition (7°C)	COP _d (declared COP)				5.12	4.74	5.47	5.16	
		Power input		kW		0.34	0.39	0.50	0.53	
		Pd _h (declared heating cap)		kW		1.96	2.05	2.51	2.55	
	D Condition (12°C)	COP _d (declared COP)				6.12	5.85	6.91	6.28	
		Power input		kW		0.32	0.35	0.36	0.41	
		Pd _h (declared heating cap)		kW		1.96	2.05	2.51	2.55	
	Power consumption in other than active mode	Crankcase heater mode	Cooling	PCK	kW	-		0.000		-
Heating			PCK	kW	-		0.000		-	
Off mode		Cooling	POFF	kW	-		0.011		-	
		Heating	POFF	kW	-		0.011		-	
Standby mode		Cooling	PSB	kW	-		0.011		-	
		Heating	PSB	kW	-		0.011		-	
Thermo-stat-off mode		Cooling	PTO	kW	-		0.005		-	
		Heating	PTO	kW	-		0.015		-	
Indication if the heater is equipped with a supplementary heater (pair application)							No		-	
Supplementary heater (pair application)	Back-up capacity	Heating	elbu	kW	-		0.0		-	
Cooling	C _{dc} (Degradation cooling)				-		0.25		-	
Heating	C _{dh} (Degradation heating)				-		0.25		-	
Cooling function included							Yes		-	
Heating function included							Yes		-	
Average climate included							Yes		-	
Cold season included							No		-	
Warm season included							No		-	

(1)Nominal cooling capacities are based on: indoor temperature: 27°CDB, 19°CWB, outdoor temperature: 35°CDB, equivalent refrigerant piping: 5m, level difference: 0m. |

(2)Nominal heating capacities are based on: indoor temperature: 20°CDB, outdoor temperature: 7°CDB, 6°CWB, equivalent refrigerant piping: 5m, level difference: 0m.

2 Specifications

2 - 1 Specifications

2

Technical specifications				FDA125A + RZAG125NY1	
Cooling capacity	Nom.		kW	12.1 (1)	
Heating capacity	Nom.		kW	13.5 (2)	
Space cooling	Capacity	Pdesign	kW	12.1	
	SEER			6.59	
	$\eta_{s,c}$		%	261	
	Annual energy consumption		kWh/a	1,102	
Space heating (Average climate)	Capacity	Pdesign	kW	9.52	
	SCOP/A			4.35	
	SCOPnet/A			4.35	
	$\eta_{s,h}$		%	171	
	Annual energy consumption		kWh/a	3,064	
	Required back up heating cap at design conditions		kW	0.00	
Space cooling	A Condition (35°C - 27/19)	Pdc	kW	12.10	
		EERd		3.25	
		Power input	kW	3.73	
	B Condition (30°C - 27/19)	Pdc	kW	8.92	
		EERd		4.99	
		Power input	kW	1.79	
	C Condition (25°C - 27/19)	Pdc	kW	5.73	
		EERd		7.67	
		Power input	kW	0.75	
	D Condition (20°C - 27/19)	Pdc	kW	3.34	
		EERd		11.04	
		Power input	kW	0.30	
Space heating (Average climate)	TOL	Tol (temperature operating limit)	°C	-10	
		Pdh (declared heating cap)	kW	9.52	
		COPd (declared COP)		1.99	
		Power input	kW	4.78	
	TBivalent	Tbiv (bivalent temperature)	°C	-10	
		Pdh (declared heating cap)	kW	9.52	
		COPd (declared COP)		1.99	
		Power input	kW	4.78	
	A Condition (-7°C)	Pdh (declared heating cap)	kW	8.42	
		COPd (declared COP)		2.69	
		Power input	kW	3.13	
	B Condition (2°C)	Pdh (declared heating cap)	kW	5.12	
Space heating (Average climate)	B Condition (2°C)	COPd (declared COP)		4.33	
		Power input	kW	1.18	
	C Condition (7°C)	Pdh (declared heating cap)	kW	3.29	
		COPd (declared COP)		5.73	
		Power input	kW	0.58	
	D Condition (12°C)	Pdh (declared heating cap)	kW	2.58	
		COPd (declared COP)		6.68	
		Power input	kW	0.39	
Power consumption in other than active mode	Crankcase heater mode	Cooling	PCK	kW	0.000
		Heating	PCK	kW	0.000
	Off mode	Cooling	POFF	kW	0.012
		Heating	POFF	kW	0.012
	Standby mode	Cooling	PSB	kW	0.012
		Heating	PSB	kW	0.012
	Thermo-stat-off mode	Cooling	PTO	kW	0.005
		Heating	PTO	kW	0.016
	Indication if the heater is equipped with a supplementary heater (pair application)				No
	Supplementary heater (pair application)	Back-up capacity	Heating	elbu	kW
Cooling	Cdc (Degradation cooling)				0.25
Heating	Cdh (Degradation heating)				0.25
Cooling function included				Yes	
Heating function included				Yes	
Average climate included				Yes	
Cold season included				No	
Warm season included				No	

(1)Nominal cooling capacities are based on: indoor temperature: 27°CDB, 19°CWB, outdoor temperature: 35°CDB, equivalent refrigerant piping: 5m, level difference: 0m. |

(2)Nominal heating capacities are based on: indoor temperature: 20°CDB, outdoor temperature: 7°CDB, 6°CWB, equivalent refrigerant piping: 5m, level difference: 0m.

2 Specifications

2 - 1 Specifications

Technical specifications				FAA71B + RZAG71NY1	FAA100B + RZAG71NY1	FAA100B + RZAG100NY1
Cooling capacity	Nom.	kW	6.80	6.80 (1)	9.50	
	Nom.	Btu/h	23,200	-	32,400	
	Nom.	kcal/h	5,847	-	8,169	
Heating capacity	Nom.	kW	7.50	7.50 (2)	10.80	
	Nom.	Btu/h	25,600	-	36,900	
	Nom.	kcal/h	6,449	-	9,286	
Power input	Cooling	kW	2.08	-	2.93	
	Heating	kW	2.19	-	3.41	
Nominal efficiency	EER		3.27	-	3.24	
	COP		3.42	-	3.17	
	Annual energy consumption	kWh	1,040	-	1,466	
	Energy labeling	Cooling	A	-	A	
	Directive	Heating	B	-	D	
Space cooling	Energy efficiency class			A++		
	Capacity	Pdesign kW	6.80		9.50	
	SEER		6.58	6.43	6.42	
	Annual energy consumption	kWh/a	362	370	518	
Space heating (Average climate)	Energy efficiency class			A+		
	Capacity	Pdesign kW	4.70		7.80	
	SCOP/A		4.20	4.10	4.01	
	SCOPnet/A		4.20	4.10	4.01	
	Pdh Heating capacity at -10°	kW	4.70	-	7.80	
	Annual energy consumption	kWh/a	1,567	1,605	2,725	
	Required back up heating cap at design conditions	kW		0.00		
Space cooling	A Condition	Pdc kW	6.80		9.50	
	(35°C - 27/19)	EERd	3.27	3.47	3.24	
		Power input	2.08	1.96	2.93	
	B Condition	Pdc kW	5.02	5.03	7.00	
	(30°C - 27/19)	EERd	5.04	5.22	4.59	
		Power input	1.00	0.96	1.53	
	C Condition	Pdc kW	3.23	3.20	4.51	
	(25°C - 27/19)	EERd	8.40	7.90	7.56	
		Power input	0.38	0.40	0.60	
	D Condition	Pdc kW	2.59	2.48	3.10	
	(20°C - 27/19)	EERd	11.70	10.59	13.20	
		Power input	0.22		0.23	
Space heating (Average climate)	TOL	Tol (temperature operating limit) °C		-10		
		Pdh (declared heating cap) kW	4.70		7.80	
		COPd (declared COP)	2.51	2.74	2.19	
		Power input	1.87	1.71	3.56	
	TBivalent	Tbiv (bivalent temperature) °C		-10		
		Pdh (declared heating cap) kW	4.70		7.80	
		COPd (declared COP)	2.51	2.74	2.19	
		Power input	1.87	1.71	3.56	
	A Condition (-7°C)	Pdh (declared heating cap) kW	4.16	4.14	6.91	
		COPd (declared COP)	2.60	3.07	2.32	
		Power input	1.60	1.35	2.98	
	B Condition (2°C)	Pdh (declared heating cap) kW	2.57	2.54	4.20	
		COPd (declared COP)	4.28	4.11	4.06	
		Power input	0.60	0.62	1.03	
	C Condition (7°C)	Pdh (declared heating cap) kW	1.83	1.79	2.70	
		COPd (declared COP)	5.26	4.81	5.24	
		Power input	0.35	0.37	0.52	
	D Condition (12°C)	Pdh (declared heating cap) kW	2.23	2.02	2.43	
		COPd (declared COP)	7.10	5.94	6.37	
		Power input	0.31	0.34	0.38	
	Power consumption in other than active mode	Crankcase heater mode	Cooling PCK kW		0.000	
			Heating PCK kW		0.000	
		Off mode	Cooling POFF kW		0.009	
			Heating POFF kW		0.009	
Standby mode		Cooling PSB kW		0.009		
		Heating PSB kW		0.009		
Thermo-stat-off mode		Cooling PTO kW		0.005		
		Heating PTO kW		0.013		
Indication if the heater is equipped with a supplementary heater (pair application)				-	No	-
Supplementary heater (pair application)	Back-up capacity	Heating elbu kW	-	0.0	-	
Cooling	Cdc (Degradation cooling)			0.25		
Heating	Cdh (Degradation heating)			0.25		
Cooling function included					Yes	

2 Specifications

2 - 1 Specifications

2

Technical specifications					FAA71B + RZAG71NY1	FAA100B + RZAG71NY1	FAA100B + RZAG100NY1
Heating function included						Yes	
Average climate included						Yes	
Cold season included						No	
Warm season included						No	
Eurovent	Sound power level outdoor	Cooling	Nom.	dBA	64	-	66
		Cooling	Nom.	dBA	61	-	65
	Piping length	Cooling	Measuring condition	m	7.50	-	

(1)Nominal cooling capacities are based on: indoor temperature: 27°CDB, 19°CWB, outdoor temperature: 35°CDB, equivalent refrigerant piping: 5m, level difference: 0m. |

(2)Nominal heating capacities are based on: indoor temperature: 20°CDB, outdoor temperature: 7°CDB, 6°CWB, equivalent refrigerant piping: 5m, level difference: 0m.

Technical specifications					FHA71A9 + RZAG71NY1	FHA100A + RZAG71NY1	FHA100A + RZAG100NY1		
Cooling capacity	Nom.			kW	6.80 (1)		9.50 (1)		
Heating capacity	Nom.			kW	7.50 (2)		10.8 (2)		
Space cooling	Energy efficiency class				A++				
	Capacity	Pdesign		kW	6.80		9.50		
	SEER				7.11	6.69	6.42		
	Annual energy consumption			kWh/a	335	356	518		
Space heating (Average climate)	Energy efficiency class				A+				
	Capacity	Pdesign		kW	4.70		7.80		
	SCOP/A				4.32	4.26	4.61		
	SCOPnet/A				4.32	4.26	4.61		
	Annual energy consumption			kWh/a	1,523	1,545	2,369		
	Required back up heating cap at design conditions			kW		0.00			
	Space cooling	A Condition	Pdc		kW	6.80		9.50	
(35°C - 27/19)		EERd			3.75	4.02	4.10		
		Power input		kW	1.81	1.69	2.31		
B Condition		Pdc		kW	5.03		7.03		
(30°C - 27/19)		EERd			5.46	5.34	4.92		
		Power input		kW	0.92	0.94	1.43		
C Condition		Pdc		kW	3.20		4.47		
(25°C - 27/19)		EERd			8.99	8.27	7.62		
		Power input		kW	0.36	0.39	0.59		
D Condition		Pdc		kW	2.48	2.62	3.54		
(20°C - 27/19)		EERd			12.58	10.71	10.27		
		Power input		kW	0.20	0.24	0.34		
Space heating (Average climate)	TOL	Tol (temperature operating limit)		°C		-10			
		Pdh (declared heating cap)		kW	4.70		7.80		
		COPd (declared COP)			2.43	2.90	2.65		
		Power input		kW	1.93	1.62	2.94		
	TBivalent	Tbiv (bivalent temperature)		°C		-10			
		Pdh (declared heating cap)		kW	4.70		7.80		
		COPd (declared COP)			2.43	2.90	2.65		
		Power input		kW	1.93	1.62	2.94		
	A Condition (-7°C)	Pdh (declared heating cap)			kW	4.14		6.86	
		COPd (declared COP)			2.95	3.26	3.03		
		Power input		kW	1.40	1.27	2.27		
	B Condition (2°C)	Pdh (declared heating cap)			kW	2.54		4.21	
	Space heating (Average climate)	B Condition (2°C)	COPd (declared COP)			4.44	4.32	4.61	
			Power input		kW	0.57	0.59	0.91	
		C Condition (7°C)	Pdh (declared heating cap)			kW	1.79	1.84	2.73
			COPd (declared COP)			5.15	4.90	5.70	
			Power input		kW	0.35	0.38	0.48	
		D Condition (12°C)	Pdh (declared heating cap)			kW	1.97	2.07	2.54
	COPd (declared COP)			5.99	6.00	7.06			
	Power input		kW	0.33	0.34	0.36			

2 Specifications

2 - 1 Specifications

Technical specifications					FHA71A9 + RZAG71NY1	FHA100A + RZAG71NY1	FHA100A + RZAG100NY1
Power consumption in other than active mode	Crankcase heater mode	Cooling	PCK	kW		0.000	
		Heating	PCK	kW		0.000	
	Off mode	Cooling	POFF	kW		0.009	
		Heating	POFF	kW		0.009	
	Standby mode	Cooling	PSB	kW		0.009	
		Heating	PSB	kW		0.009	
	Thermo-stat-off mode	Cooling	PTO	kW		0.005	
		Heating	PTO	kW		0.013	
Indication if the heater is equipped with a supplementary heater (pair application)						No	
Supplementary heater (pair application)	Back-up capacity	Heating	elbu	kW		0.0	
Cooling	Cdc (Degradation cooling)					0.25	
Heating	Cdh (Degradation heating)					0.25	
Cooling function included						Yes	
Heating function included						Yes	
Average climate included						Yes	
Cold season included						No	
Warm season included						No	

2

Technical specifications					FHA140A + RZAG100NY1	FHA125A + RZAG125NY1	FHA140A + RZAG140NY1	
Cooling capacity	Nom.			kW	9.50 (1)	12.1 (1)	13.4 (1)	
Heating capacity	Nom.			kW	10.8 (2)	13.5 (2)	15.5 (2)	
Space cooling	Energy efficiency class				A++		-	
	Capacity	Pdesign		kW	9.50	12.1	13.4	
	SEER				7.35	7.14	6.42	
	ηs,c			%	-	283	254	
	Annual energy consumption			kWh/a	453	1,017	1,253	
Space heating (Average climate)	Energy efficiency class				A+		-	
	Capacity	Pdesign		kW	7.80		9.52	
	SCOP/A				4.50	4.20	4.30	
	SCOPnet/A				4.50	4.20	4.30	
	ηs,h			%	-	165	169	
	Annual energy consumption			kWh/a	2,429	3,174	3,100	
	Required back up heating cap at design conditions			kW		0.00		
	Space cooling	A Condition (35°C - 27/19)	Pdc		kW	9.50	12.10	13.40
EERd					4.05	3.40	3.11	
Power input				kW	2.34	3.56	4.31	
B Condition (30°C - 27/19)		Pdc		kW	7.03	8.92	9.87	
		EERd			6.03	5.55	4.94	
		Power input		kW	1.17	1.61	2.00	
C Condition (25°C - 27/19)		Pdc		kW	4.46	5.73	6.35	
		EERd			8.88	8.20	7.48	
		Power input		kW	0.50	0.70	0.85	
D Condition (20°C - 27/19)		Pdc		kW	3.61	3.36	3.35	
		EERd			11.63	12.00	10.13	
		Power input		kW	0.31	0.28	0.33	
Space heating (Average climate)	TOL	Tol (temperature operating limit)			°C		-10	
		Pd _h (declared heating cap)			kW	7.80		9.52
		COP _d (declared COP)				2.85	1.87	2.13
		Power input			kW	2.73	5.10	4.47
	TBivalent	T _{biv} (bivalent temperature)			°C		-10	
		Pd _h (declared heating cap)			kW	7.80		9.52
		COP _d (declared COP)				2.85	1.87	2.13
		Power input			kW	2.73	5.10	4.47
	A Condition (-7°C)	Pd _h (declared heating cap)			kW	6.86		8.42
		COP _d (declared COP)				3.15	2.55	2.70

2 Specifications

2 - 1 Specifications

2

Technical specifications				FHA140A + RZAG100NY1	FHA125A + RZAG125NY1	FHA140A + RZAG140NY1	
Space heating (Average climate)	A Condition (-7°C)	Power input	kW	2.18	3.30	3.11	
		B Condition (2°C)	Pdh (declared heating cap)	kW	4.21	5.12	
	C Condition (7°C)	COPd (declared COP)		4.57	4.26	4.33	
		Power input	kW	0.92	1.20	1.18	
		Pdh (declared heating cap)	kW	2.73	3.29		
	D Condition (12°C)	COPd (declared COP)		5.30	5.49	5.54	
		Power input	kW	0.52	0.60	0.59	
		Pdh (declared heating cap)	kW	2.60	2.55	2.64	
	Power consumption in other than active mode	Crankcase heater mode	Cooling PCK	kW		0.000	
			Heating PCK	kW		0.000	
Off mode		Cooling POFF	kW		0.009		
		Heating POFF	kW		0.009		
Standby mode		Cooling PSB	kW		0.009		
		Heating PSB	kW		0.009		
Thermo-stat-off mode		Cooling PTO	kW		0.005		
		Heating PTO	kW		0.013		
Indication if the heater is equipped with a supplementary heater (pair application)				No			
Supplementary heater (pair application) capacity		Back-up Heating elbu	kW		0.0		
	Cooling Cdc (Degradation cooling)		0.25				
Heating	Cdh (Degradation heating)	0.25					
Cooling function included				Yes			
Heating function included				Yes			
Average climate included				Yes			
Cold season included				No			
Warm season included				No			

(1)Nominal cooling capacities are based on: indoor temperature: 27°CDB, 19°CWB, outdoor temperature: 35°CDB, equivalent refrigerant piping: 5m, level difference: 0m. |

(2)Nominal heating capacities are based on: indoor temperature: 20°CDB, outdoor temperature: 7°CDB, 6°CWB, equivalent refrigerant piping: 5m, level difference: 0m.

Technical specifications				FUA71A + RZAG71NY1	FUA100A + RZAG71NY1	FUA100A + RZAG100NY1	FUA125A + RZAG125NY1	
Cooling capacity	Nom.	kW		6.80 (1)		9.50 (1)	12.1 (1)	
Heating capacity	Nom.	kW		7.50 (2)		10.8 (2)	13.5 (2)	
Space cooling	Energy efficiency class			A++				
	Capacity	Pdesign	kW	6.80		9.50	12.1	
	SEER			7.02	6.89	6.42	6.39	
	η _{s,c}		%		-		253	
	Annual energy consumption		kWh/a	339	345	518	1,136	
Space heating (Average climate)	Energy efficiency class			A+				
	Capacity	Pdesign	kW	4.70		7.80	9.52	
	SCOP/A			4.20	4.28	4.50	4.26	
	SCOPnet/A			4.20	4.28	4.50	4.26	
	η _{s,h}		%		-		167	
	Annual energy consumption		kWh/a	1,567	1,538	2,427	3,129	
	Required back up heating cap at design conditions				0.00			
Space cooling	A Condition (35°C - 27/19)	Pdc	kW	6.80		9.50	12.10	
		EERd		3.83	4.02	3.57	3.02	
		Power input	kW	1.77	1.69	2.66	4.00	
	B Condition (30°C - 27/19)	Pdc	kW	5.03		7.03	8.91	
		EERd		5.34	5.65	4.93	5.08	
		Power input	kW	0.94	0.89	1.43	1.76	
	C Condition (25°C - 27/19)	Pdc	kW	3.20	3.19	4.46	5.74	
		EERd		8.83	8.54	7.75	7.22	
		Power input	kW	0.36	0.37	0.58	0.79	
	D Condition (20°C - 27/19)	Pdc	kW	2.59	2.64	3.36	3.23	
		EERd		12.48	10.88	10.65	10.56	
		Power input	kW	0.21	0.24	0.32	0.31	
	Space heating (Average climate)	TOL	Tol (temperature operating limit)		°C			
Pdh (declared heating cap)			kW	4.70		7.80	9.52	
COPd (declared COP)				2.58	2.95	2.62	1.97	
Power input			kW	1.82	1.59	2.97	4.83	
TBivalent		Tbiv (bivalent temperature)		°C				-10
		Pdh (declared heating cap)	kW	4.70		7.80	9.52	
		COPd (declared COP)		2.58	2.95	2.62	1.97	
		Power input	kW	1.82	1.59	2.97	4.83	
A Condition (-7°C)		Pdh (declared heating cap)	kW	4.14		6.86	8.43	
		COPd (declared COP)		2.99	3.31	3.00	2.66	

2 Specifications

2 - 1 Specifications

Technical specifications				FUA71A + RZAG71NY1	FUA100A + RZAG71NY1	FUA100A + RZAG100NY1	FUA125A + RZAG125NY1	
Space heating (Average climate)	A Condition (-7°C)	Power input	kW	1.38	1.25	2.29	3.17	
	B Condition (2°C)	Pdh (declared heating cap)	kW	2.54			4.21	5.12
		COPd (declared COP)		4.27	4.36	4.53	4.31	
		Power input	kW	0.60	0.58	0.93	1.19	
	C Condition (7°C)	Pdh (declared heating cap)	kW	1.80	1.86	2.73	3.29	
		COPd (declared COP)		5.03	4.87	5.47		
		Power input	kW	0.36	0.38	0.50	0.60	
	D Condition (12°C)	Pdh (declared heating cap)	kW	2.00	2.09	2.55	2.58	
		COPd (declared COP)		6.00	5.94	6.76	6.18	
		Power input	kW	0.33	0.35	0.38	0.42	
Power consumption in other than active mode	Crankcase heater	Cooling PCK	kW	0.000				
		Heating PCK	kW	0.000				
	Off mode	Cooling POFF	kW	0.009				
		Heating POFF	kW	0.009				
	Standby mode	Cooling PSB	kW	0.009				
		Heating PSB	kW	0.009				
	Thermo-stat-off mode	Cooling PTO	kW	0.005				
		Heating PTO	kW	0.013				
	Indication if the heater is equipped with a supplementary heater (pair application)				No			
	Supplementary heater (pair application) capacity	Back-up Heating elbu	kW	0.0				
Cooling Cdc (Degradation cooling)			0.25					
Heating	Cdh (Degradation heating)		0.25					
Cooling function included				Yes				
Heating function included				Yes				
Average climate included				Yes				
Cold season included				No				
Warm season included				No				

(1) Nominal cooling capacities are based on: indoor temperature: 27°CDB, 19°CWB, outdoor temperature: 35°CDB, equivalent refrigerant piping: 5m, level difference: 0m. |

(2) Nominal heating capacities are based on: indoor temperature: 20°CDB, outdoor temperature: 7°CDB, 6°CWB, equivalent refrigerant piping: 5m, level difference: 0m.

Technical specifications			FVA71A + RZAG71NY1	FVA100A + RZAG71NY1	FVA100A + RZAG100NY1	FVA140A + RZAG100NY1	FVA125A + RZAG125NY1	FVA140A + RZAG140NY1	
Cooling capacity	Nom.	kW	6.80 (1)		9.50 (1)		12.1 (1)	13.4 (1)	
Heating capacity	Nom.	kW	7.50 (2)		10.8 (2)		13.5 (2)	15.5 (2)	
Space cooling	Energy efficiency class		A++						
	Capacity	Pdesign	6.80		9.50		12.1	13.4	
	SEER		6.34	6.41	6.40	6.43	6.41	6.12	
	η _{s,c}	%	-						
	Annual energy consumption	kWh/a	376	371	520	517	1,133	1,314	
Space heating (Average climate)	Energy efficiency class		A+						
	Capacity	Pdesign	4.70		7.80		9.52		
	SCOP/A		4.05	4.03	4.20	4.05	4.15	3.94	
	SCOPnet/A		4.05	4.03	4.20	4.05	4.15	3.94	
	η _{s,h}	%	-						
	Annual energy consumption	kWh/a	1,625	1,634	2,600	2,697	3,209	3,383	
	Required back up heating cap at design conditions		kW	0.00					
Space cooling	A Condition (35°C - 27/19)	Pdc	6.80		9.50		12.10	13.40	
		EERd	3.27	3.95	3.57	3.93	3.21	3.03	
		Power input	2.08	1.72	2.66	2.42	3.77	4.42	
	B Condition (30°C - 27/19)	Pdc	5.03		7.03		8.92	9.87	
		EERd	5.15	5.40	5.21	5.13	5.23	4.89	
		Power input	0.98	0.93	1.35	1.37	1.70	2.02	
	C Condition (25°C - 27/19)	Pdc	3.20		4.46	4.47	5.73	6.35	
		EERd	7.53	7.81	7.67	7.63	7.07	6.90	
		Power input	0.42	0.41	0.58	0.59	0.81	0.92	
	D Condition (20°C - 27/19)	Pdc	2.33	2.61	3.20	3.54	3.23	3.24	
		EERd	11.27	9.56	9.85	10.01	10.28	9.46	
		Power input	0.21	0.27	0.33	0.35	0.31	0.34	
	Space heating (Average climate)	TOL	Tol (temperature operating limit)	-10					
			Pdh (declared heating cap)	4.70		7.80		9.52	
			COPd (declared COP)	2.42	2.85	2.45	2.57	1.86	
Power input			1.94	1.65	3.19	3.04	5.11		
TBivalent		Tbiv (bivalent temperature)	-10						
		Pdh (declared heating cap)	4.70		7.80		9.52		
		COPd (declared COP)	2.42	2.85	2.45	2.57	1.86		
		Power input	1.94	1.65	3.19	3.04	5.11		
A Condition (-7°C)		Pdh (declared heating cap)	4.14		6.86		8.43	8.42	
		COPd (declared COP)	2.83	3.18	2.82	2.84	2.55	2.42	

2 Specifications

2 - 1 Specifications

2

Technical specifications				FVA71A + RZAG71NY1	FVA100A + RZAG71NY1	FVA100A + RZAG100NY1	FVA140A + RZAG100NY1	FVA125A + RZAG125NY1	FVA140A + RZAG140NY1	
Space heating (Average climate)	A Condition (-7°C)	Power input	kW	1.46	1.30	2.43	2.42	3.30	3.48	
		Pdh (declared heating cap)	kW	2.54		4.21		5.12		
	B Condition (2°C)	COPd (declared COP)		4.07	4.11	4.21	4.11	4.20	3.99	
		Power input	kW	0.62		1.00	1.02	1.22	1.28	
	C Condition (7°C)	Pdh (declared heating cap)	kW	1.76	1.88	2.73		3.29		
		COPd (declared COP)		4.92	4.54	5.13	4.77	5.42	5.12	
		Power input	kW	0.36	0.41	0.53	0.57	0.61	0.64	
	D Condition (12°C)	Pdh (declared heating cap)	kW	1.96	2.10	2.56	2.60	2.57	2.61	
		COPd (declared COP)		5.77	5.48	6.22	5.58	6.00	5.67	
		Power input	kW	0.34	0.38	0.41	0.47	0.43	0.46	
Power consumption in other than active mode	Crankcase heater mode	Cooling PCK	kW	0.000						
		Heating PCK	kW	0.000						
	Off mode	Cooling POFF	kW	0.009						
		Heating POFF	kW	0.009						
	Standby mode	Cooling PSB	kW	0.009						
		Heating PSB	kW	0.009						
	Thermo-stat-off mode	Cooling PTO	kW	0.005						
		Heating PTO	kW	0.013						
	Indication if the heater is equipped with a supplementary heater (pair application)				No					
	Supplementary heater (pair application)	Back-up capacity	Heating elbu	kW	0.0					
Cooling Cdc (Degradation cooling)				0.25						
Heating	Cdh (Degradation heating)		0.25							
Cooling function included				Yes						
Heating function included				Yes						
Average climate included				Yes						
Cold season included				No						
Warm season included				No						

(1)Nominal cooling capacities are based on: indoor temperature: 27°CDB, 19°CWB, outdoor temperature: 35°CDB, equivalent refrigerant piping: 5m, level difference: 0m. |

(2)Nominal heating capacities are based on: indoor temperature: 20°CDB, outdoor temperature: 7°CDB, 6°CWB, equivalent refrigerant piping: 5m, level difference: 0m.

3 Electrical data

3 - 1 Electrical Data

RZAG-NV1 RZAG-NY1

Notes

1. The ·RLA· is based on the following conditions.

Cooling

Indoor temperature ·27.0°C DB / ·19.0°C WB
Outdoor temperature ·35.0°C DB

Heating

Indoor temperature ·20.0°C DB
Outdoor temperature ·7.0°C DB / ·6.0°C WB

2. ·TOCA· is the total value of each overcurrent set.

3. Voltage range

The units are suitable for use with electrical systems in which the voltage supplied to the unit terminals is not below or above the listed range limits.

4. The maximum allowable voltage that is unbalanced between phases is ·2·%.

5. ·MCA· is the maximum input current.

The capacity of the ·MFA· must be greater than that of the ·MCA·.

Select the ·MFA· according to the table.

6. Select the wire size according to the MCA.

7. ·MFA· is used to select the circuit breaker and the ground fault circuit interruptor.

Earth leakage circuit breaker

3D120943E

RZAG71-140N7Y1

Indoor	Outdoor	Power supply	Voltage range	MCA	TOCA	MFA	Compressor			OFM		IFM	
							MSC	RLA	kW	FLA	kW	FLA	kW
FCAG71HVEB	RZAG71N7Y1B	3N-50Hz 380-415V	Minimum: 342 V Maximum: 457 V	11.1	—	16	—	—	9.2	0.234	0.8	0.091	0.7
FCAG35BVEB x2	RZAG71N7Y1B			11.0	—	16	—	9.2	0.234	0.8	0.044 x2	0.3 x2	
FCAG71BVEB	RZAG71N7Y1B			10.8	—	16	—	9.2	0.234	0.8	0.054	0.4	
FFA35A2VEB x2	RZAG71N7Y1B			10.8	—	16	—	9.2	0.234	0.8	0.050 x2	0.2 x2	
FBA35A2VEB x2	RZAG71N7Y1B			13.2	—	16	—	9.2	0.234	0.8	0.089 x2	1.4 x2	
FBA71A2VEB	RZAG71N7Y1B			11.7	—	16	—	9.2	0.234	0.8	0.070	1.3	
FNA35A2VEB x2	RZAG71N7Y1B			11.4	—	16	—	9.2	0.234	0.8	0.034 x2	0.5 x2	
FUA71AVEB9	RZAG71N7Y1B			11.3	—	16	—	9.2	0.234	0.8	0.046	0.9	
FAA71BUV1B	RZAG71N7Y1B			10.5	—	16	—	9.2	0.234	0.8	0.048	0.5	
FVA71AMVEB	RZAG71N7Y1B			11.2	—	16	—	9.2	0.234	0.8	0.117	0.8	
FDXM35F3V1B x2	RZAG71N7Y1B		11.0	—	16	—	9.2	0.234	0.8	0.034 x2	0.3 x2		
FHA35AVEB98 x2	RZAG71N7Y1B		11.6	—	16	—	9.2	0.234	0.8	0.090 x2	0.6 x2		
FHA71AVEB98	RZAG71N7Y1B		11.2	—	16	—	9.2	0.234	0.8	0.110	0.8		
FCAG100HVEB	RZAG100N7Y1B		3N-50Hz 380-415V	Minimum: 342 V Maximum: 457 V	14.9	—	16	—	11.8	0.234	1.2	0.221	1.3
FCAG35BVEB x3	RZAG100N7Y1B				13.0	—	16	—	10.4	0.234	1.2	0.044 x3	0.3 x3
FCAG100BVEB	RZAG100N7Y1B				12.7	—	16	—	10.4	0.234	1.2	0.039 x3	0.3 x2
FFA50A2VEB x2	RZAG100N7Y1B				14.2	—	16	—	11.8	0.234	1.2	0.117	0.7
FBA50A2VEB x3	RZAG100N7Y1B				12.7	—	16	—	10.4	0.234	1.2	0.050 x3	0.2 x3
FFA50A2VEB x2	RZAG100N7Y1B				12.9	—	16	—	10.4	0.234	1.2	0.050 x2	0.4 x2
FBA35A2VEB x2	RZAG100N7Y1B				16.3	—	20	—	10.4	0.234	1.2	0.089 x3	1.4 x3
FBA50A2VEB x2	RZAG100N7Y1B	14.9			—	16	—	10.4	0.234	1.2	0.089 x2	1.4 x2	
FBA100A2VEB	RZAG100N7Y1B	17.0			—	20	—	11.8	0.234	1.2	0.127	3.5	
FNA35A2VEB x3	RZAG100N7Y1B	13.6			—	16	—	10.4	0.234	1.2	0.034 x3	0.5 x3	
FNA50A2VEB x2	RZAG100N7Y1B	13.1		—	16	—	10.4	0.234	1.2	0.060 x2	0.5 x2		
FUA100AVEB9	RZAG100N7Y1B	14.9		—	16	—	11.8	0.234	1.2	0.106	1.3		
FAA100BUV1B	RZAG100N7Y1B	14.4		—	16	—	11.8	0.234	1.2	0.064	0.9		
FVA100AMVEB	RZAG100N7Y1B	15.1		—	16	—	11.8	0.234	1.2	0.238	1.5		
FDXM35F3V1B x3	RZAG100N7Y1B	13.0		—	16	—	10.4	0.234	1.2	0.034 x3	0.3 x3		
FDXM50F3V1B x2	RZAG100N7Y1B	13.9		—	16	—	10.4	0.234	1.2	0.060 x2	0.9 x2		
FHA35AVEB98 x3	RZAG100N7Y1B	13.9		—	16	—	10.4	0.234	1.2	0.090 x3	0.6 x3		
FHA50AVEB98 x2	RZAG100N7Y1B	13.3		—	16	—	10.4	0.234	1.2	0.090 x2	0.6 x2		
FHA100AVEB8	RZAG100N7Y1B	14.9		—	16	—	11.8	0.234	1.2	0.172	1.3		

Indoor	Outdoor	Power supply	Voltage range	MCA	TOCA	MFA	Compressor			OFM		IFM	
							MSC	RLA	kW	FLA	kW	FLA	kW
FCAG71HVEB	RZAG71N7Y1B	3N-50Hz 380-415V	Minimum: 342 V Maximum: 457 V	15.0	—	16	—	—	11.8	0.234	1.2	0.244	1.4
FCAG35BVEB x4	RZAG71N7Y1B			12.2	—	16	—	9.3	0.234	1.2	0.044 x4	0.3 x4	
FCAG50BVEB x3	RZAG71N7Y1B			12.9	—	16	—	10.3	0.234	1.2	0.039 x3	0.3 x3	
FCAG60BVEB x2	RZAG71N7Y1B			14.1	—	16	—	11.8	0.234	1.2	0.044 x2	0.3 x2	
FCAG125BVEB	RZAG71N7Y1B			14.6	—	16	—	11.8	0.234	1.2	0.168	1.0	
FFA35A2VEB x4	RZAG71N7Y1B			11.8	—	16	—	9.3	0.234	1.2	0.050 x4	0.2 x4	
FFA50A2VEB x3	RZAG71N7Y1B			13.2	—	16	—	10.3	0.234	1.2	0.050 x3	0.4 x3	
FFA60A2VEB x2	RZAG71N7Y1B			14.8	—	16	—	11.8	0.234	1.2	0.050 x2	0.6 x2	
FBA35A2VEB x4	RZAG71N7Y1B			16.5	—	20	—	9.3	0.234	1.2	0.089 x4	1.4 x4	
FBA50A2VEB x3	RZAG71N7Y1B			16.2	—	20	—	10.3	0.234	1.2	0.089 x3	1.4 x3	
FBA60A2VEB x2	RZAG71N7Y1B		16.1	—	20	—	11.8	0.234	1.2	0.070 x2	1.3 x2		
FBA125A2VEB	RZAG71N7Y1B		17.4	—	20	—	11.8	0.234	1.2	0.187	3.9		
FNA35A2VEB x4	RZAG71N7Y1B		13.0	—	16	—	9.3	0.234	1.2	0.034 x4	0.5 x4		
FNA50A2VEB x3	RZAG71N7Y1B		13.5	—	16	—	10.3	0.234	1.2	0.060 x3	0.5 x3		
FNA60A2VEB x2	RZAG71N7Y1B		14.8	—	16	—	11.8	0.234	1.2	0.060 x2	0.6 x2		
FUA125AVEB9	RZAG71N7Y1B		15.0	—	16	—	11.8	0.234	1.2	0.106	1.4		
FVA125AMVEB	RZAG71N7Y1B		15.7	—	16	—	11.8	0.234	1.2	0.350	2.1		
FBA125AVEB8	RZAG71N7Y1B		15.1	—	16	—	11.8	0.234	1.2	0.238	1.5		
FDXM35F3V1B x4	RZAG71N7Y1B		12.2	—	16	—	9.3	0.234	1.2	0.034 x4	0.3 x4		
FDXM50F3V1B x3	RZAG71N7Y1B		14.8	—	16	—	10.3	0.234	1.2	0.060 x3	0.9 x3		
FDXM60F3V1B x2	RZAG71N7Y1B	15.4	—	16	—	11.8	0.234	1.2	0.060 x2	0.9 x2			
FHA35AVEB98 x4	RZAG71N7Y1B	13.4	—	16	—	9.3	0.234	1.2	0.090 x4	0.6 x4			
FHA50AVEB98 x3	RZAG71N7Y1B	13.8	—	16	—	10.3	0.234	1.2	0.090 x3	0.6 x3			
FHA60AVEB98 x2	RZAG71N7Y1B	14.8	—	16	—	11.8	0.234	1.2	0.091 x2	0.6 x2			
FHA125AVEB8	RZAG71N7Y1B	15.1	—	16	—	11.8	0.234	1.2	0.217	1.5			
FCAG71HVEB	RZAG140N7Y1B	3N-50Hz 380-415V	Minimum: 342 V Maximum: 457 V	15.0	—	16	—	11.6	0.234	1.4	0.091 x2	0.7 x2	
FCAG140HVEB	RZAG140N7Y1B			15.0	—	16	—	11.6	0.234	1.4	0.244	1.4	
FCAG35BVEB x4	RZAG140N7Y1B			12.2	—	16	—	9.1	0.234	1.4	0.044 x4	0.3 x4	
FCAG50BVEB x3	RZAG140N7Y1B			12.9	—	16	—	10.1	0.234	1.4	0.039 x3	0.3 x3	
FCAG71BVEB x2	RZAG140N7Y1B			14.4	—	16	—	11.6	0.234	1.4	0.054 x2	0.4 x2	
FCAG140BVEB	RZAG140N7Y1B			14.9	—	16	—	11.6	0.234	1.4	0.164	1.3	
FFA35A2VEB x4	RZAG140N7Y1B			11.8	—	16	—	9.1	0.234	1.4	0.050 x4	0.2 x4	
FFA50A2VEB x3	RZAG140N7Y1B			13.2	—	16	—	10.1	0.234	1.4	0.050 x3	0.4 x3	
FBA35A2VEB x4	RZAG140N7Y1B			16.5	—	20	—	9.1	0.234	1.4	0.089 x4	1.4 x4	
FBA50A2VEB x3	RZAG140N7Y1B			16.2	—	20	—	10.1	0.234	1.4	0.089 x3	1.4 x3	
FBA71A2VEB x2	RZAG140N7Y1B		16.1	—	20	—	11.6	0.234	1.4	0.070 x2	1.3 x2		
FBA140A2VEB	RZAG140N7Y1B		17.4	—	20	—	11.6	0.234	1.4	0.187	3.9		
FNA35A2VEB x4	RZAG140N7Y1B		13.0	—	16	—	9.1	0.234	1.4	0.034 x4	0.5 x4		
FNA50A2VEB x3	RZAG140N7Y1B		13.5	—	16	—	10.1	0.234	1.4	0.060 x3	0.5 x3		
FUA71AVEB9	RZAG140N7Y1B		15.4	—	16	—	11.6	0.234	1.4	0.046 x2	0.9 x2		
FAA71BUV1B	RZAG140N7Y1B		14.6	—	16	—	11.6	0.234	1.4	0.048 x2	0.5 x2		
FVA71AMVEB	RZAG140N7Y1B		15.2	—	16	—	11.6	0.234	1.4	0.117 x2	0.8 x2		
FVA140AMVEB	RZAG140N7Y1B		15.4	—	16	—	11.6	0.234	1.4	0.276	1.8		
FDXM35F3V1B x4	RZAG140N7Y1B		12.2	—	16	—	9.1	0.234	1.4	0.034 x4	0.3 x4		
FDXM50F3V1B x3	RZAG140N7Y1B		14.8	—	16	—	10.1	0.234	1.4	0.060 x3	0.9 x3		
FHA35AVEB98 x4	RZAG140N7Y1B	13.4	—	16	—	9.1	0.234	1.4	0.090 x4	0.6 x4			
FHA50AVEB98 x3	RZAG140N7Y1B	13.8	—	16	—	10.1	0.234	1.4	0.090 x3	0.6 x3			
FHA71AVEB98	RZAG140N7Y1B	15.2	—	16	—	11.6	0.234	1.4	0.110 x2	0.8 x2			
FHA140AVEB8	RZAG140N7Y1B	15.4	—	16	—	11.6	0.234	1.4	0.251	1.8			

3D120943E

3 Electrical data

3 - 1 Electrical Data

RZASG71-140N2Y1

3

Indoor	Outdoor	Power supply	Voltage range	Compressor																
				MCA	TOCA	MFA	MSC	RLA	kW	FLA	kW	FLA								
FCAG71HVEB	RZAG71N2Y1B	3N-50Hz 380-415V	Minimum: -342 V Maximum: +457 V	11.1	-	16	-	9.2	0.234	0.8	0.091	0.7								
FCAG71BVEB	RZAG71N2Y1B			10.8	-	16	-	9.2	0.234	0.8	0.054	0.4								
FFA35A2VEB	RZAG71N2Y1B			10.8	-	16	-	9.2	0.234	0.8	0.050	0.2	0.2							
FFA35A2VEB	RZAG71N2Y1B			13.2	-	16	-	9.2	0.234	0.8	0.089	0.2	1.4	0.2						
FFA71A2VEB	RZAG71N2Y1B			11.7	-	16	-	9.2	0.234	0.8	0.070	1.3								
FFA35A2VEB	RZAG71N2Y1B			11.4	-	16	-	9.2	0.234	0.8	0.034	0.2	0.5	0.2						
FUA71AVEB9	RZAG71N2Y1B			11.3	-	16	-	9.2	0.234	0.8	0.046	0.9								
FAA71BUV1B	RZAG71N2Y1B			10.9	-	16	-	9.2	0.234	0.8	0.048	0.5								
FVA71AMVEB	RZAG71N2Y1B			11.2	-	16	-	9.2	0.234	0.8	0.117	0.8								
FDXM35F3V1B	RZAG71N2Y1B			11.0	-	16	-	9.2	0.234	0.8	0.034	0.2	0.3	0.2						
FHA35AVEB98	RZAG71N2Y1B		11.6	-	16	-	9.2	0.234	0.8	0.090	0.2	0.6	0.2							
FHA71AVEB98	RZAG71N2Y1B		11.2	-	16	-	9.2	0.234	0.8	0.110	0.8									
FCAG100HVEB	RZAG100N2Y1B		14.9	-	16	-	11.8	0.234	1.2	0.221	1.3									
FCAG35BVEB	RZAG100N2Y1B		13.0	-	16	-	10.4	0.234	1.2	0.044	0.3	0.3	0.3							
FCAG50BVEB	RZAG100N2Y1B		12.7	-	16	-	10.4	0.234	1.2	0.039	0.2	0.3	0.2							
FCAG100BVEB	RZAG100N2Y1B		14.2	-	16	-	11.8	0.234	1.2	0.117	0.7									
FFA35A2VEB	RZAG100N2Y1B		12.7	-	16	-	10.4	0.234	1.2	0.050	0.3	0.2	0.3							
FFA50A2VEB	RZAG100N2Y1B		12.9	-	16	-	10.4	0.234	1.2	0.050	0.2	0.4	0.2							
FFA35A2VEB	RZAG100N2Y1B		16.3	-	20	-	10.4	0.234	1.2	0.089	1.4	0.3	0.3							
FFA50A2VEB	RZAG100N2Y1B		14.9	-	16	-	10.4	0.234	1.2	0.089	1.2	0.3	0.2							
FBA100A2VEB	RZAG100N2Y1B	17.0	-	20	-	11.8	0.234	1.2	0.127	1.5										
FFA35A2VEB	RZAG100N2Y1B	13.6	-	16	-	10.4	0.234	1.2	0.034	0.3	0.5	0.3								
FFA50A2VEB	RZAG100N2Y1B	13.1	-	16	-	10.4	0.234	1.2	0.060	0.2	0.5	0.2								
FUA100AVEB9	RZAG100N2Y1B	14.9	-	16	-	11.8	0.234	1.2	0.106	1.3										
FAA100BUV1B	RZAG100N2Y1B	14.4	-	16	-	11.8	0.234	1.2	0.064	0.9										
FVA100AMVEB	RZAG100N2Y1B	15.1	-	16	-	11.8	0.234	1.2	0.238	1.5										
FDXM35F3V1B	RZAG100N2Y1B	13.0	-	16	-	10.4	0.234	1.2	0.034	0.3	0.3	0.3								
FDXM50F3V1B	RZAG100N2Y1B	13.9	-	16	-	10.4	0.234	1.2	0.060	0.2	0.3	0.2								
FHA35AVEB98	RZAG100N2Y1B	13.9	-	16	-	10.4	0.234	1.2	0.090	0.2	0.6	0.3								
FHA50AVEB98	RZAG100N2Y1B	13.3	-	16	-	10.4	0.234	1.2	0.090	0.2	0.6	0.2								
FHA100AVEB8	RZAG100N2Y1B	14.9	-	16	-	11.8	0.234	1.2	0.172	1.3										

Symbols
MCA: Minimum Circuit Ampere [A]
TOCA: Total overcurrent amps [A]
MFA: Maximum Fuse Ampere [A]
MSC: Maximum current of the starting compressor [A]
RLA: Rated load amps [A]
OFM: Outdoor fan motor
IFM: Indoor fan motor
FLA: Full Load Ampere [A]
KW: Fan motor rated output [kW]

Indoor	Outdoor	Power supply	Voltage range	Compressor																
				MCA	TOCA	MFA	MSC	RLA	kW	FLA	kW	FLA								
FCAG125HVEB	RZAG125N2Y1B	3N-50Hz 380-415V	Minimum: -342 V Maximum: +457 V	15.0	-	16	-	11.8	0.234	1.2	0.244	1.4								
FCAG35BVEB	RZAG125N2Y1B			12.2	-	16	-	9.3	0.234	1.2	0.044	0.3	0.4							
FCAG50BVEB	RZAG125N2Y1B			12.9	-	16	-	10.3	0.234	1.2	0.039	0.3	0.3							
FCAG60BVEB	RZAG125N2Y1B			14.1	-	16	-	11.8	0.234	1.2	0.044	0.2	0.3	0.2						
FFA35A2VEB	RZAG125N2Y1B			14.6	-	16	-	9.3	0.234	1.2	0.168	1.0								
FFA50A2VEB	RZAG125N2Y1B			11.8	-	16	-	9.3	0.234	1.2	0.050	0.4	0.2	0.4						
FFA60A2VEB	RZAG125N2Y1B			13.2	-	16	-	10.3	0.234	1.2	0.050	0.3	0.4	0.3						
FFA71A2VEB	RZAG125N2Y1B			14.8	-	16	-	11.8	0.234	1.2	0.050	0.2	0.6	0.2						
FFA35A2VEB	RZAG125N2Y1B			16.5	-	20	-	9.3	0.234	1.2	0.089	0.4	1.4	0.4						
FFA50A2VEB	RZAG125N2Y1B			16.2	-	20	-	10.3	0.234	1.2	0.089	0.3	1.4	0.3						
FFA60A2VEB	RZAG125N2Y1B		16.1	-	20	-	11.8	0.234	1.2	0.070	0.2	1.3	0.2							
FFA71A2VEB	RZAG125N2Y1B		17.4	-	20	-	11.8	0.234	1.2	0.187	0.9									
FBA125A2VEB	RZAG125N2Y1B		13.0	-	16	-	9.3	0.234	1.2	0.034	0.4	0.5	0.4							
FFA50A2VEB	RZAG125N2Y1B		13.5	-	16	-	10.3	0.234	1.2	0.060	0.3	0.5	0.3							
FFA60A2VEB	RZAG125N2Y1B		14.8	-	16	-	11.8	0.234	1.2	0.060	0.2	0.6	0.2							
FUA125AVEB9	RZAG125N2Y1B		15.0	-	16	-	11.8	0.234	1.2	0.106	1.4									
FUA125AVEB9	RZAG125N2Y1B		15.7	-	16	-	11.8	0.234	1.2	0.350	2.1									
FVA125AMVEB	RZAG125N2Y1B		15.1	-	16	-	11.8	0.234	1.2	0.238	1.5									
FDXM35F3V1B	RZAG125N2Y1B		12.2	-	16	-	9.3	0.234	1.2	0.034	0.3	0.4	0.3							
FDXM50F3V1B	RZAG125N2Y1B		14.8	-	16	-	10.3	0.234	1.2	0.060	0.3	0.9	0.3							
FHA35AVEB98	RZAG125N2Y1B	15.4	-	16	-	11.8	0.234	1.2	0.060	0.2	0.9	0.2								
FHA50AVEB98	RZAG125N2Y1B	13.4	-	16	-	9.3	0.234	1.2	0.090	0.4	0.6	0.4								
FHA60AVEB98	RZAG125N2Y1B	13.8	-	16	-	10.3	0.234	1.2	0.090	0.3	0.6	0.3								
FHA71AVEB98	RZAG125N2Y1B	14.8	-	16	-	11.8	0.234	1.2	0.090	0.2	0.6	0.2								
FUA125AVEB8	RZAG125N2Y1B	15.1	-	16	-	11.8	0.234	1.2	0.217	1.5										
FUA125AVEB8	RZAG125N2Y1B	15.0	-	16	-	11.6	0.234	1.4	0.091	0.2	0.7	0.2								
FVA125AMVEB	RZAG125N2Y1B	15.0	-	16	-	11.6	0.234	1.4	0.244	1.4										
FDXM35F3V1B	RZAG140N2Y1B	12.2	-	16	-	9.1	0.234	1.4	0.044	0.3	0.4									
FDXM50F3V1B	RZAG140N2Y1B	12.9	-	16	-	10.1	0.234	1.4	0.039	0.3	0.3									
FHA35AVEB98	RZAG140N2Y1B	14.4	-	16	-	11.6	0.234	1.4	0.054	0.2	0.4	0.2								
FHA50AVEB98	RZAG140N2Y1B	14.9	-	16	-	11.6	0.234	1.4	0.168	1.3										
FHA60AVEB98	RZAG140N2Y1B	11.8	-	16	-	9.1	0.234	1.4	0.050	0.4	0.2	0.4								
FHA71AVEB98	RZAG140N2Y1B	13.2	-	16	-	10.1	0.234	1.4	0.050	0.3	0.4	0.3								
FFA35A2VEB	RZAG140N2Y1B	16.5	-	20	-	9.1	0.234	1.4	0.089	0.4	1.4	0.4								
FFA50A2VEB	RZAG140N2Y1B	16.2	-	20	-	10.1	0.234	1.4	0.089	0.3	1.4	0.3								
FFA60A2VEB	RZAG140N2Y1B	16.1	-	20	-	11.6	0.234	1.4	0.070	0.2	1.3	0.2								
FFA71A2VEB	RZAG140N2Y1B	17.4	-	20	-	11.6	0.234	1.4	0.187	0.9										
FBA140A2VEB	RZAG140N2Y1B	13.0	-	16	-	9.1	0.234	1.4	0.034	0.4	0.5	0.4								
FFA50A2VEB	RZAG140N2Y1B	13.5	-	16	-	10.1	0.234	1.4	0.060	0.3	0.5	0.3								
FFA60A2VEB	RZAG140N2Y1B	15.4	-	16	-	11.6	0.234	1.4	0.046	0.2	0.9	0.2								
FFA71A2VEB	RZAG140N2Y1B	14.6	-	16	-	11.6	0.234</													

3 Electrical data

3 - 1 Electrical Data

RZAG71-140N7Y1

Indoor	Outdoor	Power supply	Voltage range	Compressor																	
				MCA	TOCA	MFA	MSC	RLA	kw	FLA	kw	FLA									
FCAGH100HVEB	RZAG71N7Y1B	3N-50Hz-380-415V	Minimum: -342 V- Maximum: -457 V-	11.8	-	16	-	9.2	0.234	0.8	0.221	1.3	11.3	-	16	-	9.2	0.234	0.8	0.044 x3	0.3 x3
FCAG35BVEB	x3 RZAG71N7Y1B			11.0	-	16	-	9.2	0.234	0.8	0.039 x2	0.3 x2	11.1	-	16	-	9.2	0.234	0.8	0.117	0.7
FCAG100BVEB	x2 RZAG71N7Y1B			11.0	-	16	-	9.2	0.234	0.8	0.050 x3	0.2 x3	11.2	-	16	-	9.2	0.234	0.8	0.050 x2	0.4 x2
FFA35A2VEB	x3 RZAG71N7Y1B			14.6	-	16	-	9.2	0.234	0.8	0.089 x3	1.4 x3	13.2	-	16	-	9.2	0.234	0.8	0.089 x2	1.4 x2
FFA50A2VEB	x2 RZAG71N7Y1B			13.9	-	16	-	9.2	0.234	0.8	0.127	3.5	11.8	-	16	-	9.2	0.234	0.8	0.106	1.3
FBA50A2VEB	x3 RZAG71N7Y1B			11.3	-	16	-	9.2	0.234	0.8	0.064	0.9	12.0	-	16	-	9.2	0.234	0.8	0.238	1.5
FBA100A2VEB	x2 RZAG71N7Y1B			11.3	-	16	-	9.2	0.234	0.8	0.034 x3	0.3 x3	12.3	-	16	-	9.2	0.234	0.8	0.060 x2	0.9 x2
FUA100AVEB9	RZAG71N7Y1B			12.3	-	16	-	9.2	0.234	0.8	0.090 x3	0.6 x3	11.6	-	16	-	9.2	0.234	0.8	0.090 x2	0.6 x2
FVA100AMVEB	RZAG71N7Y1B			11.8	-	16	-	9.2	0.234	0.8	0.172	1.3	13.5	-	16	-	10.4	0.234	1.2	0.091 x2	0.7 x2
FDMX35F3V1B	x3 RZAG71N7Y1B			13.3	-	16	-	10.4	0.234	1.2	0.044 x4	0.3 x4	13.3	-	16	-	10.4	0.234	1.2	0.039 x3	0.3 x3
FDMX50F3V1B	x2 RZAG71N7Y1B			12.9	-	16	-	10.4	0.234	1.2	0.054 x2	0.4 x2	13.0	-	16	-	10.4	0.234	1.2	0.039 x3	0.3 x3
FHA35AVEB98	x3 RZAG71N7Y1B			14.9	-	16	-	11.8	0.234	1.2	0.168	1.3	12.9	-	16	-	10.4	0.234	1.2	0.054 x2	0.4 x2
FHA50AVEB98	x2 RZAG71N7Y1B			12.9	-	16	-	10.4	0.234	1.2	0.050 x4	0.8	14.9	-	16	-	11.8	0.234	1.2	0.168	1.3
FHA140AVEB8	x2 RZAG71N7Y1B			13.3	-	16	-	10.4	0.234	1.2	0.039 x3	0.3 x3	13.3	-	16	-	10.4	0.234	1.2	0.050 x3	0.4 x3
FCAG140BVEB	x2 RZAG100N7Y1B			17.7	-	20	-	10.4	0.234	1.2	0.089 x4	1.4 x4	17.7	-	20	-	10.4	0.234	1.2	0.089 x3	1.4 x3
FFA35A2VEB	x4 RZAG100N7Y1B			16.3	-	20	-	10.4	0.234	1.2	0.089 x3	1.4 x3	14.7	-	16	-	10.4	0.234	1.2	0.070 x2	1.3 x2
FFA50A2VEB	x3 RZAG100N7Y1B			14.7	-	16	-	10.4	0.234	1.2	0.070 x2	1.3 x2	17.4	-	20	-	11.8	0.234	1.2	0.187	3.9
FBA50A2VEB	x3 RZAG100N7Y1B			13.9	-	16	-	10.4	0.234	1.2	0.046 x2	0.9 x2	13.1	-	16	-	10.4	0.234	1.2	0.048 x2	0.5 x2
FBA100A2VEB	x2 RZAG100N7Y1B	15.4	-	16	-	11.8	0.234	1.2	0.276	1.8	13.1	-	16	-	10.4	0.234	1.2	0.048 x2	0.5 x2		
FUA100AVEB9	x2 RZAG100N7Y1B	13.3	-	16	-	10.4	0.234	1.2	0.034 x4	0.3 x4	14.6	-	16	-	11.8	0.234	1.4	0.091 x2	0.7 x2		
FVA100AMVEB	x2 RZAG100N7Y1B	14.9	-	16	-	10.4	0.234	1.2	0.060 x3	0.9 x3	14.6	-	16	-	10.4	0.234	1.2	0.090 x4	0.6 x4		
FDMX35F3V1B	x4 RZAG100N7Y1B	14.6	-	16	-	10.4	0.234	1.2	0.090 x4	0.6 x4	13.9	-	16	-	10.4	0.234	1.2	0.090 x3	0.6 x3		
FDMX50F3V1B	x3 RZAG100N7Y1B	13.9	-	16	-	10.4	0.234	1.2	0.110 x2	0.8 x2	13.7	-	16	-	10.4	0.234	1.2	0.110 x2	0.8 x2		
FHA35AVEB98	x4 RZAG100N7Y1B	15.4	-	16	-	11.8	0.234	1.2	0.251	1.8											

Indoor	Outdoor	Power supply	Voltage range	Compressor																	
				MCA	TOCA	MFA	MSC	RLA	kw	FLA	kw	FLA									
FCAGH71HVEB	x2 RZAG125N7Y1B	3N-50Hz-380-415V	Minimum: -342 V- Maximum: -457 V-	15.0	-	16	-	11.8	0.234	1.2	0.091 x2	0.7 x2	15.0	-	16	-	11.8	0.234	1.2	0.244	1.4
FCAG140HVEB	x2 RZAG125N7Y1B			12.2	-	16	-	9.3	0.234	1.2	0.044 x4	0.3 x4	12.9	-	16	-	10.3	0.234	1.2	0.039 x3	0.3 x3
FCAG35BVEB	x4 RZAG125N7Y1B			14.4	-	16	-	11.8	0.234	1.2	0.054 x2	0.4 x2	14.4	-	16	-	11.8	0.234	1.2	0.168	1.3
FCAG50BVEB	x3 RZAG125N7Y1B			14.9	-	16	-	11.8	0.234	1.2	0.050 x4	0.2 x4	11.8	-	16	-	9.3	0.234	1.2	0.050 x4	0.2 x4
FCAG71BVEB	x2 RZAG125N7Y1B			13.2	-	16	-	10.3	0.234	1.2	0.050 x3	0.4 x3	16.5	-	20	-	9.3	0.234	1.2	0.089 x4	1.4 x4
FFA35A2VEB	x4 RZAG125N7Y1B			16.2	-	20	-	10.3	0.234	1.2	0.089 x3	1.4 x3	16.2	-	20	-	10.3	0.234	1.2	0.089 x3	1.4 x3
FFA50A2VEB	x3 RZAG125N7Y1B			16.1	-	20	-	11.8	0.234	1.2	0.070 x2	1.3 x2	17.4	-	20	-	11.8	0.234	1.2	0.187	3.9
FBA50A2VEB	x3 RZAG125N7Y1B			15.4	-	16	-	11.8	0.234	1.2	0.046 x2	0.9 x2	14.6	-	16	-	11.8	0.234	1.2	0.048 x2	0.5 x2
FBA100A2VEB	x2 RZAG125N7Y1B			15.4	-	16	-	11.8	0.234	1.2	0.276	1.8	15.4	-	16	-	11.8	0.234	1.2	0.276	1.8
FUA100AVEB9	x2 RZAG125N7Y1B			12.2	-	16	-	9.3	0.234	1.2	0.034 x4	0.3 x4	14.8	-	16	-	10.3	0.234	1.2	0.060 x3	0.9 x3
FVA100AMVEB	x2 RZAG125N7Y1B			14.8	-	16	-	10.3	0.234	1.2	0.090 x4	0.6 x4	13.4	-	16	-	9.3	0.234	1.2	0.090 x2	0.6 x2
FDMX35F3V1B	x4 RZAG125N7Y1B			13.4	-	16	-	10.3	0.234	1.2	0.090 x3	0.6 x3	13.8	-	16	-	10.3	0.234	1.2	0.090 x3	0.6 x3
FDMX50F3V1B	x3 RZAG125N7Y1B			15.2	-	16	-	11.8	0.234	1.2	0.110 x2	0.8 x2	15.2	-	16	-	11.8	0.234	1.2	0.110 x2	0.8 x2
FHA140AVEB8	x2 RZAG125N7Y1B			15.4	-	16	-	11.8	0.234	1.2	0.251	1.8	15.4	-	16	-	11.8	0.234	1.2	0.251	1.8
FCAGH71HVEB	x2 RZAG140N7Y1B			15.0	-	16	-	11.6	0.234	1.4	0.091 x2	0.7 x2	15.0	-	16	-	11.6	0.234	1.4	0.091 x2	0.7 x2
FCAG140HVEB	x2 RZAG140N7Y1B			15.0	-	16	-	11.6	0.234	1.4	0.244	1.4	12.2	-	16	-	9.1	0.234	1.4	0.044 x4	0.3 x4
FCAG35BVEB	x4 RZAG140N7Y1B			12.2	-	16	-	10.1	0.234	1.4	0.039 x3	0.3 x3	12.9	-	16	-	10.1	0.234	1.4	0.039 x3	0.3 x3
FCAG50BVEB	x3 RZAG140N7Y1B			14.4	-	16	-	11.6	0.234	1.4	0.054 x2	0.4 x2	14.4	-	16	-	11.6	0.234	1.4	0.054 x2	0.4 x2
FCAG71BVEB	x2 RZAG140N7Y1B	14.9	-	16	-	11.6	0.234	1.4	0.168	1.3	14.9	-	16	-	11.6	0.234	1.4	0.168	1.3		
FFA35A2VEB	x4 RZAG140N7Y1B	11.8	-	16	-	9.1	0.234	1.4	0.050 x4	0.2 x4	11.8	-	16	-	9.1	0.234	1.4	0.050 x4	0.2 x4		
FFA50A2VEB	x3 RZAG140N7Y1B	13.2	-	16	-	10.1	0.234	1.4	0.050 x3	0.4 x3	16.5	-	20	-	9.1	0.234	1.4	0.089 x3	1.4 x3		
FBA50A2VEB	x3 RZAG140N7Y1B	16.2	-	20	-	10.1	0.234	1.4	0.089 x3	1.4 x3	16.2	-	20	-	10.1	0.234	1.4	0.089 x3	1.4 x3		
FBA100A2VEB	x2 RZAG140N7Y1B	16.1	-	20	-	11.6	0.234	1.4	0.070 x2	1.3 x2	16.1	-	20	-	11.6	0.234	1.4	0.070 x2	1.3 x2		
FUA100AVEB9	x2 RZAG140N7Y1B	17.4	-	20	-	11.6	0.234	1.4	0.187	3.9	17.4	-	20	-	11.6	0.234	1.4	0.187	3.9		
FVA100AMVEB	x2 RZAG140N7Y1B	15.4	-	16	-	11.6	0.234	1.4	0.046 x2	0.9 x2	15.4	-	16	-	11.6	0.234	1.4	0.046 x2	0.9 x2		
FDMX35F3V1B	x4 RZAG140N7Y1B	14.6	-	16	-	11.6	0.234	1.4	0.048 x2	0.5 x2	14.6	-	16	-	11.6	0.234	1.4	0.048 x2	0.5 x2		
FDMX50F3V1B	x3 RZAG140N7Y1B	15.4	-	16	-	11.6	0.234	1.4	0.276	1.8	15.4	-	16	-	11.6	0.234	1.4	0.276	1.8		
FHA140AVEB8	x2 RZAG140N7Y1B	12.2	-	16	-	9.1	0.234	1.4	0.034 x4	0.3 x4	14.8	-	16	-	10.1	0.234	1.4	0.060 x3	0.9 x3		
FHA35AVEB98	x4 RZAG140N7Y1B	14.8	-	16	-	10.1	0.234	1.4	0.090 x4	0.6 x4	13.4	-	16	-	9.1	0.234	1.4	0.090 x4	0.6 x4		
FHA50AVEB98	x3 RZAG140N7Y1B	13.8	-	16	-	10.1	0.234	1.4	0.090 x3	0.6 x3	13.8	-	16	-	10.1	0.234	1.4	0.090 x3	0.6 x3		
FHA71AVEB98	x2 RZAG140N7Y1B	15.2	-	16	-	11.6	0.234	1.4	0.110 x2	0.8 x2	15.2	-	16	-	11.6	0.234	1.4	0.110 x2	0.8 x2		
FHA140AVEB8	x2 RZAG140N7Y1B	15.4	-	16	-	11.6	0.234	1.4	0.251	1.8	15.4	-	16	-	11.6	0.234	1.4	0.251	1.8		

3D120944F

RZAG71-140N2Y1

Indoor	Outdoor	Power supply	Voltage range	Compressor																	
				MCA	TOCA	MFA	MSC	RLA	kw	FLA	kw	FLA									
FCAGH100HVEB	RZAG71N2Y1B	3N-50Hz-380-415V	Minimum: -342 V- Maximum: -457 V-	11.8	-	16	-	9.2	0.234	0.8	0.221	1.3	11.3	-	16	-	9.2	0.234	0.8	0.044 x3	0.3 x3
FCAG35BVEB	x3 RZAG71N2Y1B			11.0	-	16	-	9.2	0.234	0.8	0.039 x2	0.3 x2	11.1	-	16	-	9.2	0.234	0.8	0.117	0.7
FCAG100BVEB	x2 RZAG71N2Y1B			11.0	-	16	-	9.2	0.234	0.8	0.050 x3	0.2 x3	11.2	-	16	-	9.2	0.234	0.8	0.050 x2	0.4 x2
FFA35A2VEB	x3 RZAG71N2Y1B			14.6	-	16	-	9.2	0.234	0.8	0.089 x3	1.4 x3	13.2	-	16	-	9.2	0.234	0.8	0.089 x2	1.4 x2
FFA50A2VEB	x2 RZAG71N2Y1B			13.9	-	16	-	9.2	0.234	0.8	0.127	3.5	11.8	-	1						

4 Options

4 - 1 Options

4
RZAG-NV1
RZAG-NY1

Available options for ·RZAG· models

Option			Option kit			
			RZAG71N7V1B	RZAG100N7V1B	RZAG125N7V1B	RZAG140N7V1B
			RZAG71N7Y1B	RZAG100N7Y1B	RZAG125N7Y1B	RZAG140N7Y1B
			RZAG71N2V1B	RZAG100N2V1B	RZAG125N2V1B	RZAG140N2V1B
			RZAG71N2Y1B	RZAG100N2Y1B	RZAG125N2Y1B	RZAG140N2Y1B
Bottom plate heater			EKBPH140N			
Refrigerant branch piping	Twin	(2)	KHRQ(M)58T			
	Triple	(2)	KHRQ(M)58H			
	Double twin	(2)	-	KHRQ(M)58T (3x)		
Demand adaptor kit		(1)	SB.KRP58M52 (KRP58M51 + EKMKA2)			
Sound reduction kit			EKLN140A1			

Notes

- (1) To mount ·KRP58M51·, an additional mounting kit (·EKMKA2·) needs to be used (obligatory). This will be offered as sales bom SB.·KRP58M52· = ·KRP58M51· + ·EKMKA2·.
- (2) KHRQ* is branch piping for imperial pipe sizes, KHRQM* for metric pipe sizes.

3D120932D

6 Capacity tables

6 - 1 Cooling/Heating Capacity Tables

6

RZAG71NV1 RZAG71NY1

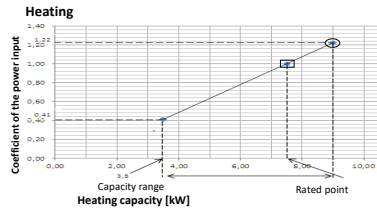
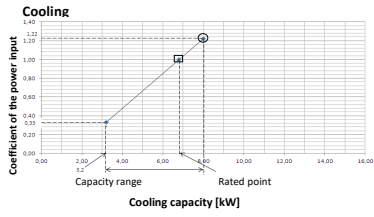

- Symbols**
 AFR: Air flow rate [m³/min]
 BF: Bypass factor
 EWB: Entering wet-bulb temperature [°C WB]
 EDB: Entering dry-bulb temperature [°C DB]
 TC: Maximum total cooling/heating capacity [kW]
 SHC: Sensible heat capacity [kW]
 CPI: Coefficient of the power input compressor + indoor and outdoor fan motors

Cooling	Indoor	Outdoor temperature [°C DB]											
		25			30			35			40		
		TC	SHC	CPI	TC	SHC	CPI	TC	SHC	CPI	TC	SHC	CPI
[°C WB]	[°C DB]	[kW]											
16.0	22	8.03	5.45	1.00	7.76	5.32	1.11	7.48	5.20	1.21	7.21	5.06	1.32
18.0	25	8.40	5.45	1.00	8.11	5.32	1.11	7.83	5.19	1.22	7.54	5.05	1.33
19.0	27	8.59	5.44	1.01	8.30	5.32	1.12	8.00	5.18	1.22	7.70	5.05	1.33
19.5	27	8.68	5.43	1.01	8.39	5.31	1.12	8.09	5.17	1.22	7.79	5.05	1.33
22.0	30	9.15	5.38	1.01	8.84	5.25	1.12	8.52	5.13	1.23	8.21	4.99	1.34
24.0	32	9.53	5.31	1.03	9.20	5.19	1.13	8.87	5.06	1.25	8.54	4.92	1.35

Heating	Indoor	Outdoor temperature [°C WB]																	
		-15			-10			-5			0			6			10		
		TC	CPI	TC	SHC	CPI	TC	SHC	CPI	TC	SHC	CPI	TC	SHC	CPI	TC	SHC	CPI	TC
[°C DB]	[°C WB]	[kW]																	
16	6.44	0.93	7.09	0.99	7.55	1.02	7.79	1.06	9.00	1.12	9.71	1.19							
18	6.43	0.98	7.08	1.03	7.54	1.07	7.78	1.10	9.00	1.17	9.71	1.24							
20	6.42	1.01	7.07	1.07	7.53	1.12	7.77	1.14	9.00	1.22	9.71	1.28							
21	6.42	1.03	7.07	1.09	7.53	1.13	7.77	1.16	9.00	1.24	9.71	1.31							
22	6.42	1.05	7.06	1.11	7.52	1.15	7.76	1.19	9.00	1.27	9.71	1.33							
24	6.41	1.09	7.05	1.15	7.51	1.20	7.75	1.23	9.00	1.32	9.67	1.38							

- Notes**
 1. The ratings shown are net capacities which include a correction for indoor fan motor heat.
 2. ○ = Maximum at standard conditions
 □ = Rated capacity and rated coefficient of the power input
 The maximum capacity is not guaranteed except at standard conditions.
 3. -SHC is based on indoor units -EWB & EDB.
 -SHC for other dry-bulb temperatures = SHC + SHC*
 SHC* = -SHC correction for other dry-bulb temperatures
 = 0.02 x AFR (m³/min) x (1-BF) x (DB* - EDB)
 4. The capacities are based on the following conditions:
 Outdoor air: -85% RH
 However, the outdoor ambient condition of the rated capacity during heating operation is -7°C DB / 6°C WB.
 Corresponding refrigerant piping length: -5.0 m
 Level difference: -0 m
 5. -CPI is a percentage value compared to the rated value which is -1.00%.
 6. The error rate for this value is less than -5% and depends on the indoor unit type.
 7. The heating performance takes into account the drop that occurs during defrost operation.
 8. The air flow rate and bypass factor are mentioned in the table.
 9. The rated power input for each model is mentioned in the table below.

Pair	FCAGH71H	FCAG71B	FAA71B	FVA71A	FHA71A	FUA71A	FBA71A
Cooling	1.65	1.92	2.08	2.08	1.81	1.77	2.00
Heating	1.60	2.02	2.19	2.21	1.90	1.73	1.99

Twin	FCAG35B X 2	FHA35A X 2	FFA35A X 2	FDXM35F X 2	FBA35A X 2	FNA35A X 2
Cooling	1.56	1.53	1.75	1.64	1.67	1.68
Heating	1.59	1.69	2.25	1.84	1.90	1.86

Pair	FCAGH71H	FCAG71B	FAA71B	FVA71A	FHA71A	FUA71A	FBA71A
AFR	21.2	15.3	18.0	18.0	20.5	23.0	18.0
(BF)	(0.20)	(0.14)	(0.16)	(0.16)	(0.13)	(0.24)	(0.13)

Twin	FCAG35B X 2	FHA35A X 2	FFA35A X 2	FDXM35F X 2	FBA35A X 2	FNA35A X 2
AFR	12.5 x 2	14.0 x 2	10.0 x 2	8.7 x 2	15.0 x 2	8.7 x 2
(BF)	(0.40 x 2)	(0.17 x 2)	(0.25 x 2)	(0.17 x 2)	(0.08 x 2)	(0.17 x 2)

3D125180B

RZAG71NV1 RZAG71NY1

Performance characteristics for ·EDP· room

Indoor	RH [%]	°CWB	°CDB	Outdoor temperature [°C DB]																																																																																																																																																																																																																																																																																																																																																																																																																																																																																																																																																																																																																																																																																																																																																																																																		
				-20			-15			-10			-5			0			5			10			15			20			25			30			35			40																																																																																																																																																																																																																																																																																																																																																																																																																																																																																																																																																																																																																																																																																																																																																														
				TC	SHC	CPI	TC	SHC	CPI	TC	SHC	CPI	TC	SHC	CPI	TC	SHC	CPI	TC	SHC	CPI	TC	SHC	CPI	TC	SHC	CPI	TC	SHC	CPI	TC	SHC	CPI	TC	SHC	CPI																																																																																																																																																																																																																																																																																																																																																																																																																																																																																																																																																																																																																																																																																																																																																																		
41.8	11	18	4.81	4.67	0.32	4.81	4.67	0.34	4.81	4.67	0.36	4.81	4.67	0.37	4.81	4.67	0.39	4.81	4.67	0.41	4.81	4.67	0.43	4.81	4.67	0.46	4.81	4.67	0.48	4.81	4.67	0.50	4.81	4.67	0.52	4.81	4.67	0.55	4.81	4.67	0.57	4.81	4.67	0.60	4.81	4.67	0.63	4.81	4.67	0.66	4.81	4.67	0.69	4.81	4.67	0.72	4.81	4.67	0.75	4.81	4.67	0.78	4.81	4.67	0.81	4.81	4.67	0.84	4.81	4.67	0.87	4.81	4.67	0.90	4.81	4.67	0.93	4.81	4.67	0.96	4.81	4.67	0.99	4.81	4.67	1.02	4.81	4.67	1.05	4.81	4.67	1.08	4.81	4.67	1.11	4.81	4.67	1.14	4.81	4.67	1.17	4.81	4.67	1.20	4.81	4.67	1.23	4.81	4.67	1.26	4.81	4.67	1.29	4.81	4.67	1.32	4.81	4.67	1.35	4.81	4.67	1.38	4.81	4.67	1.41	4.81	4.67	1.44	4.81	4.67	1.47	4.81	4.67	1.50	4.81	4.67	1.53	4.81	4.67	1.56	4.81	4.67	1.59	4.81	4.67	1.62	4.81	4.67	1.65	4.81	4.67	1.68	4.81	4.67	1.71	4.81	4.67	1.74	4.81	4.67	1.77	4.81	4.67	1.80	4.81	4.67	1.83	4.81	4.67	1.86	4.81	4.67	1.89	4.81	4.67	1.92	4.81	4.67	1.95	4.81	4.67	1.98	4.81	4.67	2.01	4.81	4.67	2.04	4.81	4.67	2.07	4.81	4.67	2.10	4.81	4.67	2.13	4.81	4.67	2.16	4.81	4.67	2.19	4.81	4.67	2.22	4.81	4.67	2.25	4.81	4.67	2.28	4.81	4.67	2.31	4.81	4.67	2.34	4.81	4.67	2.37	4.81	4.67	2.40	4.81	4.67	2.43	4.81	4.67	2.46	4.81	4.67	2.49	4.81	4.67	2.52	4.81	4.67	2.55	4.81	4.67	2.58	4.81	4.67	2.61	4.81	4.67	2.64	4.81	4.67	2.67	4.81	4.67	2.70	4.81	4.67	2.73	4.81	4.67	2.76	4.81	4.67	2.79	4.81	4.67	2.82	4.81	4.67	2.85	4.81	4.67	2.88	4.81	4.67	2.91	4.81	4.67	2.94	4.81	4.67	2.97	4.81	4.67	3.00	4.81	4.67	3.03	4.81	4.67	3.06	4.81	4.67	3.09	4.81	4.67	3.12	4.81	4.67	3.15	4.81	4.67	3.18	4.81	4.67	3.21	4.81	4.67	3.24	4.81	4.67	3.27	4.81	4.67	3.30	4.81	4.67	3.33	4.81	4.67	3.36	4.81	4.67	3.39	4.81	4.67	3.42	4.81	4.67	3.45	4.81	4.67	3.48	4.81	4.67	3.51	4.81	4.67	3.54	4.81	4.67	3.57	4.81	4.67	3.60	4.81	4.67	3.63	4.81	4.67	3.66	4.81	4.67	3.69	4.81	4.67	3.72	4.81	4.67	3.75	4.81	4.67	3.78	4.81	4.67	3.81	4.81	4.67	3.84	4.81	4.67	3.87	4.81	4.67	3.90	4.81	4.67	3.93	4.81	4.67	3.96	4.81	4.67	3.99	4.81	4.67	4.02	4.81	4.67	4.05	4.81	4.67	4.08	4.81	4.67	4.11	4.81	4.67	4.14	4.81	4.67	4.17	4.81	4.67	4.20	4.81	4.67	4.23	4.81	4.67	4.26	4.81	4.67	4.29	4.81	4.67	4.32	4.81	4.67	4.35	4.81	4.67	4.38	4.81	4.67	4.41	4.81	4.67	4.44	4.81	4.67	4.47	4.81	4.67	4.50	4.81	4.67	4.53	4.81	4.67	4.56	4.81	4.67	4.59	4.81	4.67	4.62	4.81	4.67	4.65	4.81	4.67	4.68	4.81	4.67	4.71	4.81	4.67	4.74	4.81	4.67	4.77	4.81	4.67	4.80	4.81	4.67	4.83	4.81	4.67	4.86	4.81	4.67	4.89	4.81	4.67	4.92	4.81	4.67	4.95	4.81	4.67	4.98	4.81	4.67	5.01	4.81	4.67	5.04	4.81	4.67	5.07	4.81	4.67	5.10	4.81	4.67	5.13	4.81	4.67	5.16	4.81	4.67	5.19	4.81	4.67	5.22	4.81	4.67	5.25	4.81	4.67	5.28	4.81	4.67	5.31	4.81	4.67	5.34	4.81	4.67	5.37	4.81	4.67	5.40	4.81	4.67	5.43	4.81	4.67	5.46	4.81	4.67	5.49	4.81	4.67	5.52	4.81	4.67	5.55	4.81	4.67	5.58	4.81	4.67	5.61	4.81	4.67	5.64	4.81	4.67	5.67	4.81	4.67	5.70	4.81	4.67	5.73	4.81	4.67	5.76	4.81	4.67	5.79	4.81	4.67	5.82	4.81	4.67	5.85	4.81	4.67	5.88	4.81	4.67	5.91	4.81	4.67	5.94	4.81	4.67	5.97	4.81	4.67	6.00	4.81	4.67	6.03	4.81	4.67	6.06	4.81	4.67	6.09	4.81	4.67	6.12	4.81	4.67	6.15	4.81	4.67	6.18	4.81	4.67	6.21	4.81	4.67	6.24	4.81	4.67	6.27	4.81	4.67	6.30	4.81	4.67	6.33	4.81	4.67	6.36	4.81	4.67	6.39	4.81	4.67	6.42	4.81	4.67	6.45	4.81	4.67	6.48	4.81	4.67	6.51	4.81	4.67	6.54	4.81	4.67	6.57	4.81	4.67	6.60	4.81	4.67	6.63	4.81	4.67	6.66	4.81	4.67	6.69	4.81	4.67	6.72	4.81	4.67	6.75	4.81	4.67	6.78	4.81	4.67	6.81	4.81	4.67	6.84	4.81	4.67	6.87	4.81	4.67	6.90	4.81	4.67	6.93	4.81	4.67	6.96	4.81	4.67	6.99	4.81	4.67	7.02	4.81	4.67	7.05	4.81	4.67	7.08	4.81	4.67	7.11	4.81	4.67	7.14	4.81	4.67	7.17	4.81	4.67	7.20	4.81	4.67	7.23	4.81	4.67	7.26	4.81	4.67	7.29	4.81	4.67	7.32	4.81	4.67	7.35	4.81	4.67	7.38	4.81	4.67	7.41	4.81	4.67	7.44	4.81	4.67	7.47	4.81	4.67	7.50	4.81	4.67	7.53	4.81	4.67	7.56	4.81	4.67	7.59	4.81	4.67	7.62	4.81	4.67	7.65	4.81	4.67	7.68	4.81	4.67	7.71	4.81	4.67	7.74	4.81	4.67	7.77	4.81	4.67	7.80	4.81	4.67	7.83	4.81	4.67	7.86	4.81	4.67	7.89	

6 Capacity tables

6 - 1 Cooling/Heating Capacity Tables

RZAG100NV1 RZAG100NY1

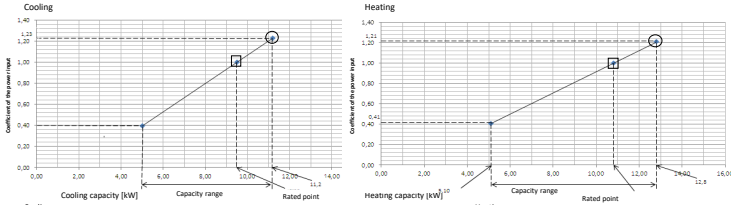

Symbols
 AFR: Air flow rate (m³/min)
 BF: Bypass factor
 EWB: Entering wet-bulb temperature [°C WB]
 EDB: Entering dry-bulb temperature [°C DB]
 TC: Maximum total cooling/heating capacity [kW]
 SHC: Sensible heat capacity [kW]
 CPI: Coefficient of the power input
 PI: Power input [kW]
 compressor + indoor and outdoor fan motors

Indoor	Outdoor temperature [°C DB]												
	25			30			35			40			
TC	SHC	CPI	TC	SHC	CPI	TC	SHC	CPI	TC	SHC	CPI		
16.0	22	11.20	7.61	1.01	10.85	7.44	1.11	10.50	7.29	1.22	10.11	7.09	1.32
18.0	25	11.80	7.59	1.01	11.37	7.49	1.12	11.00	7.27	1.23	10.55	7.09	1.33
19.0	27	12.00	7.57	1.02	11.62	7.44	1.12	11.20	7.26	1.23	10.80	7.04	1.33
19.5	27	12.15	7.59	1.02	11.74	7.37	1.13	11.43	7.34	1.23	10.93	7.04	1.34
22.0	30	12.80	7.57	1.02	12.37	7.36	1.13	11.90	7.16	1.24	11.52	7.03	1.35
24.0	32	13.30	7.42	1.03	12.88	7.27	1.14	12.40	7.06	1.25	11.97	6.93	1.36

Indoor	Outdoor temperature [°C WB]											
	-15			-10			-5			0		
TC	SHC	CPI	TC	SHC	CPI	TC	SHC	CPI	TC	SHC	CPI	
16	8.58	0.92	9.45	0.98	10.1	1.02	10.4	1.05	12.8	1.11	13.8	1.18
18	8.57	0.97	9.44	1.02	10.0	1.06	10.3	1.09	12.8	1.16	13.8	1.23
20	8.56	1.00	9.43	1.06	10.0	1.11	10.3	1.13	12.8	1.21	13.8	1.27
21	8.56	1.02	9.42	1.08	10.0	1.12	10.3	1.15	12.8	1.23	13.8	1.30
22	8.55	1.04	9.42	1.1	10.0	1.14	10.3	1.18	12.8	1.26	13.8	1.32
24	8.54	1.08	9.41	1.14	10.0	1.19	10.3	1.22	12.8	1.31	13.8	1.37

- Notes
- The ratings shown are net capacities which include a correction for indoor fan motor heat.
 - = Maximum at standard conditions
□ = Rated capacity and rated coefficient of the power input
The maximum capacity is not guaranteed except at standard conditions.
 - SHC is based on indoor units EWB & EDB.
SHC* for other dry-bulb temperatures = SHC × SHC*
SHC* = SHC correction for other dry-bulb temperatures
= 0.02 × AFR (m³/min) × (1-BF) × (DB* - EDB)
 - The capacities are based on the following conditions:
Outdoor air: 85% RH
However, the outdoor ambient condition of the rated capacity during heating operation is 7°C DB / 6°C WB.
Corresponding refrigerant piping length: 5.0 m
Level difference: 0 m
 - CPI is a percentage value compared to the rated value which is 1.00.
 - The error rate for this value is less than 5% and depends on the indoor unit type.
 - The heating performance takes into account the drop that occurs during defrost operation.

8. The air flow rate and bypass factor are mentioned in the table.

Pair	FCAG100H	FCAG100B	FAA100B	FVA100A	FMA100A	FUA100A	FBA100A
Cooling	32.3	22.8	26.0	28.0	28.0	31.0	29.0
Heating	(0.17)	(0.17)	(0.10)	(0.20)	(0.09)	(0.20)	(0.03)

Twin	FCAG50B x 2	FHA50A x 2	FFA50A x 2	FDXMS5F x 2	FBA50A x 2	FNA50A x 2
Cooling	12.6 x 2	15.0 x 2	12.0 x 2	15.8 x 2	15.0 x 2	16.0 x 2
Heating	(0.22 x 2)	(0.18 x 2)	(0.16 x 2)	(0.11 x 2)	(0.13 x 2)	(0.11 x 2)

Triple	FCAG35B x 3	FHA35A x 3	FFA35A x 3	FDXMS3F x 3	FBA35A x 3	FNA35A x 3
Cooling	12.5 x 3	14.0 x 3	10.0 x 3	8.7 x 3	15.0 x 3	8.7 x 3
Heating	(0.40 x 3)	(0.17 x 3)	(0.25 x 3)	(0.17 x 3)	(0.08 x 3)	(0.17 x 3)

9. The rated power input for each model is mentioned in the table below.

Pair	FCAG100H	FCAG100B	FAA100B	FVA100A	FMA100A	FUA100A	FBA100A
Cooling	2.25	2.65	2.93	2.66	2.31	2.66	2.58
Heating	2.16	3.01	3.41	2.73	2.72	2.68	2.79

Twin	FCAG50B x 2	FHA50A x 2	FFA50A x 2	FDXMS5F x 2	FBA50A x 2	FNA50A x 2
Cooling	2.16	2.35	2.51	2.00	2.29	2.10
Heating	2.37	2.65	2.75	2.57	2.79	2.57

Triple	FCAG35B x 3	FHA35A x 3	FFA35A x 3	FDXMS3F x 3	FBA35A x 3	FNA35A x 3
Cooling	2.05	2.03	2.23	2.11	2.20	2.17
Heating	2.16	2.15	2.76	2.91	2.32	2.91

3D125181C

RZAG100NV1 RZAG100NY1

Performance characteristics for ·EDP· room

Indoor	Outdoor temperature [°C DB]																																																			
	-20				-15				-10				-5				0				5				10				15				20				25				30				35				40			
	TC	SHC	CPI	PI	TC	SHC	CPI	PI	TC	SHC	CPI	PI	TC	SHC	CPI	PI	TC	SHC	CPI	PI	TC	SHC	CPI	PI	TC	SHC	CPI	PI	TC	SHC	CPI	PI	TC	SHC	CPI	PI	TC	SHC	CPI	PI	TC	SHC	CPI	PI	TC	SHC	CPI	PI	TC	SHC	CPI	PI
41.8	11	18	6.00	6.00	0.32	6.00	6.00	0.33	6.00	6.00	0.34	6.00	6.00	0.35	6.00	6.00	0.37	6.00	6.00	0.38	6.00	6.00	0.38	6.00	6.00	0.39	6.00	6.00	0.39	6.00	6.00	0.39	8.36	7.98	1.00	7.92	7.72	1.10	7.48	7.43	1.20	7.09	7.15	1.29								
57.0	13	18	7.48	6.37	0.42	7.48	6.37	0.42	7.48	6.37	0.44	7.48	6.37	0.45	7.48	6.37	0.46	7.48	6.37	0.46	7.48	6.37	0.46	7.48	6.37	0.46	7.48	6.37	0.46	9.71	7.67	1.00	9.30	7.42	1.11	8.90	7.16	1.21	8.45	6.88	1.30											
31.4	11	20	6.00	6.00	0.32	6.00	6.00	0.33	6.00	6.00	0.34	6.00	6.00	0.35	6.00	6.00	0.37	6.00	6.00	0.38	6.00	6.00	0.38	6.00	6.00	0.39	6.00	6.00	0.39	8.36	8.36	1.00	7.92	7.92	1.10	7.48	7.48	1.20	7.09	7.09	1.29											
44.9	13	20	7.48	7.25	0.42	7.48	7.25	0.42	7.48	7.25	0.44	7.48	7.25	0.45	7.48	7.25	0.46	7.48	7.25	0.46	7.48	7.25	0.46	7.48	7.25	0.46	7.48	7.25	0.46	9.71	8.53	1.00	9.30	8.28	1.11	8.90	8.01	1.21	8.45	7.74	1.30											
52.0	14	20	8.22	7.18	0.46	8.22	7.18	0.47	8.22	7.18	0.48	8.22	7.18	0.49	8.22	7.18	0.51	8.22	7.18	0.51	8.22	7.18	0.51	8.22	7.18	0.51	8.22	7.18	0.51	10.50	8.45	1.01	10.23	8.31	1.11	9.96	8.17	1.21	9.68	7.94	1.31											
22.9	11	22	6.00	6.00	0.32	6.00	6.00	0.33	6.00	6.00	0.34	6.00	6.00	0.35	6.00	6.00	0.37	6.00	6.00	0.38	6.00	6.00	0.38	6.00	6.00	0.39	6.00	6.00	0.39	8.36	8.36	1.00	7.92	7.92	1.10	7.48	7.48	1.20	7.09	7.09	1.29											
34.8	13	22	7.48	7.48	0.42	7.48	7.48	0.42	7.48	7.48	0.44	7.48	7.48	0.45	7.48	7.48	0.46	7.48	7.48	0.46	7.48	7.48	0.46	7.48	7.48	0.46	7.48	7.48	0.46	9.71	9.71	1.00	9.30	9.30	1.11	8.90	8.90	1.21	8.45	8.45	1.30											
47.6	15	22	8.96	7.82	0.51	8.96	7.82	0.52	8.96	7.82	0.53	8.96	7.82	0.54	8.96	7.82	0.55	8.96	7.82	0.55	8.96	7.82	0.55	8.96	7.82	0.55	8.96	7.82	0.55	11.28	9.19	1.01	10.89	8.96	1.11	10.51	8.72	1.22	10.12	8.48	1.32											
54.3	16	22	9.70	7.54	0.56	9.70	7.54	0.56	9.70	7.54	0.58	9.70	7.54	0.59	9.70	7.54	0.60	9.70	7.54	0.60	9.70	7.54	0.60	9.70	7.54	0.60	9.70	7.54	0.60	11.84	8.40	1.01	11.40	8.22	1.11	11.03	8.04	1.22	10.58	7.77	1.32											
21.2	12	24	6.74	6.74	0.37	6.74	6.74	0.38	6.74	6.74	0.39	6.74	6.74	0.40	6.74	6.74	0.41	6.74	6.74	0.42	6.74	6.74	0.42	6.74	6.74	0.42	6.74	6.74	0.42	9.04	9.04	1.00	8.61	8.61	1.10	8.19	8.19	1.21	7.77	7.77	1.30											
32.1	14	24	8.22	8.22	0.46	8.22	8.22	0.47	8.22	8.22	0.48	8.22	8.22	0.49	8.22	8.22	0.51	8.22	8.22	0.51	8.22	8.22	0.51	8.22	8.22	0.51	8.22	8.22	0.51	10.50	10.50	1.01	10.23	10.23	1.11	9.96	9.96	1.21	9.68	9.68	1.31											
43.8	16	24	9.70	8.68	0.56	9.70	8.68	0.56	9.70	8.68	0.58	9.70	8.68	0.59	9.70	8.68	0.60	9.70	8.68	0.60	9.70	8.68	0.60	9.70	8.68	0.60	9.70	8.68	0.60	11.84	9.74	1.01	11.40	9.51	1.12	11.03	9.32	1.22	10.58	9.06	1.32											
50.0	17	24	9.98	7.86	0.57	9.98	7.86	0.58	9.98	7.86	0.59	9.98	7.86	0.60	9.98	7.86	0.61	9.98	7.86	0.61	9.98	7.86	0.61	9.98	7.86	0.61	9.98	7.86	0.61	12.39	9.45	1.02	11.86	9.16	1.12	11.33	8.86	1.22	10.80	8.52	1.33											
21.5	14	27	8.22	8.22	0.46	8.22	8.22	0.47	8.22	8.22	0.48	8.22	8.22	0.49	8.22	8.22	0.51	8.22	8.22	0.51	8.22	8.22	0.51	8.22	8.22	0.51	8.22	8.22	0.51	10.50	10.50	1.01	10.23	10.23	1.11	9.96	9.96	1.21	9.68	9.68	1.31											
26.3	15	27	8.96	8.96	0.51	8.96	8.96	0.52	8.96	8.96	0.53	8.96	8.96	0.54	8.96	8.96	0.55	8.96	8.96	0.55	8.96	8.96	0.55	8.96	8.96	0.55	8.96	8.96	0.55	11.28	11.28	1.01	10.89	10.89	1.11	10.51	10.51	1.22	10.12	10.12	1.32											
31.3	16	27	9.70	9.70	0.56	9.70	9.70	0.56	9.70	9.70	0.58	9.70	9.70	0.59	9.70	9.70	0.60	9.70	9.70	0.60	9.70	9.70	0.60	9.70	9.70	0.60	9.70	9.70	0.60	11.84	11.84	1.01	11.40	11.40	1.12	11.03	11.03	1.22	10.58	10.58	1.32											

Symbols
 TC: Maximum total cooling capacity [kW]
 SHC: Sensible heat capacity [kW]
 CPI: Coefficient of the power input
 PI: Power input [kW]
 compressor + indoor and outdoor fan motors
 RH: Relative humidity [%]

- Notes
- The ratings shown are net capacities which include a deduction for indoor fan motor heat.
 - The capacities are based on the following conditions:
Outdoor air: 85% RH
Corresponding refrigerant piping length: 5.0 m
Level difference: 0 m
 - For EDP applications, it is recommended to use outdoor unit setting 2-57-2.
 - CPI is a percentage value compared to the rated value which is 1.00.
 - The error rate for this value is less than 5% and depends on the indoor unit type.

6. The rated power input for each model is mentioned in the table below.

6 Capacity tables

6 - 1 Cooling/Heating Capacity Tables

RZAG125NV1

RZAG125NY1

Cooling

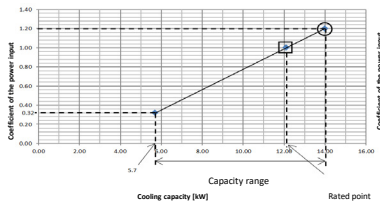

Heating

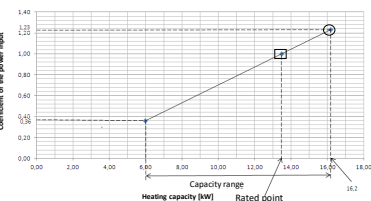

Symbols
AFR: Air flow rate [m³/min]
BF: Bypass factor
EWB: Entering wet-bulb temperature [°C WB]
EDB: Entering dry-bulb temperature [°C DB]
TC: Maximum total cooling/heating capacity [kW]
SHC: Sensible heat capacity [kW]
CPI: Coefficient of the power input
PI: Power input [kW]
compressor + indoor and outdoor fan motors

Cooling

Indoor	Outdoor temperature [°C DB]													
	25			30			35			40				
TCWB	TCDB	kW	TC	SHC	CPI	TC	SHC	CPI	TC	SHC	CPI	TC	SHC	CPI
16.0	22	14.10	9.54	0.99	13.60	9.30	1.09	13.30	9.12	1.19	12.60	8.78	1.29	
18.0	25	14.70	9.50	0.99	14.20	9.32	1.09	13.70	9.09	1.20	13.20	8.89	1.30	
19.0	27	15.00	9.52	1.00	14.50	9.34	1.10	14.00	9.06	1.20	13.50	8.97	1.31	
19.5	27	15.21	9.52	1.00	14.68	9.26	1.11	14.15	9.08	1.20	13.64	8.81	1.31	
22.0	30	16.00	9.39	1.00	15.47	9.14	1.11	14.90	8.95	1.21	14.38	8.74	1.32	
24.0	32	16.70	9.31	1.01	16.10	9.09	1.11	15.50	8.83	1.23	14.97	8.63	1.33	

- The ratings shown are net capacities which include a correction for indoor fan motor heat.
- = Maximum at standard conditions
□ = Rated capacity and rated coefficient of the power input
The maximum capacity is not guaranteed except at standard conditions.
- SHC is based on indoor units: EWB & EDB.
SHC for other dry-bulb temperatures = SHC + SHC*
SHC* = SHC correction for other dry-bulb temperatures
= 0.02 x AFR [m³/min] x (1-BF) x (DB* - EDB)
- The capacities are based on the following conditions:
Outdoor air: 85% RH
However, the outdoor ambient condition of the rated capacity during heating operation is 7°C DB / 6°C WB.
Corresponding refrigerant piping length: -5.0 m
Level difference: 0 m
5. CPI is a percentage value compared to the rated value which is 1.00.
6. The error rate for this value is less than -5% and depends on the indoor unit type.
7. The heating performance takes into account the drop that occurs during defrost operation.
8. The air flow rate and bypass factor are mentioned in the table below.

Pair

Pair	FAH610H	FAH610S	FAH612H	FAH612S	FAH614H	FAH614S	FAH616H	FAH616S
Cooling	3.15	3.06	3.21	3.27	3.56	3.48	3.70	3.70
Heating	3.08	3.02	3.26	3.34	3.58	3.49	3.80	3.75

Triple

Pair	FAH610H	FAH612H	FAH614H	FAH616H	FAH610S	FAH612S	FAH614S	FAH616S
Cooling	3.48	3.22	3.48	3.56	3.51	3.56	3.56	3.56
Heating	3.49	3.27	3.58	3.62	3.62	3.62	3.62	3.62

Double

Pair	FAH610H	FAH612H	FAH614H	FAH616H	FAH610S	FAH612S	FAH614S	FAH616S
Cooling	3.15	3.16	3.48	3.51	3.51	3.51	3.51	3.51
Heating	2.86	2.71	3.29	3.46	3.56	3.56	3.56	3.56

Double twin

Pair	FAH610H	FAH612H	FAH614H	FAH616H	FAH610S	FAH612S	FAH614S	FAH616S
Cooling	2.64	3.06	3.36	3.38	3.50	3.58	3.58	3.58

Heating

Indoor	Outdoor temperature [°C WB]													
	-15.0			-10.0			-5.0			0.0			10.0	
TCWB	TCDB	kW	TC	SHC	CPI	TC	SHC	CPI	TC	SHC	CPI	TC	SHC	CPI
16	11.0	0.94	1.01	1.00	1.00	1.03	1.02	1.06	1.02	1.06	1.13	1.15	1.20	
18	11.0	0.98	1.21	1.03	1.25	1.08	1.32	1.11	1.62	1.18	1.75	1.26		
20	11.0	1.02	1.20	1.08	1.24	1.13	1.32	1.16	1.62	1.29	1.75	1.30		
21	11.0	1.04	1.20	1.10	1.28	1.14	1.32	1.17	1.62	1.28	1.75	1.32		
22	11.0	1.06	1.20	1.12	1.28	1.16	1.32	1.20	1.62	1.28	1.74	1.34		
24	11.0	1.10	1.20	1.16	1.28	1.21	1.32	1.24	1.62	1.33	1.74	1.39		

9. The rated power input for each model is mentioned in the table below.

Pair

Pair	FAH610H	FAH612H	FAH614H	FAH616H	FAH610S	FAH612S	FAH614S	FAH616S
Cooling	3.15	3.06	3.21	3.27	3.56	3.48	3.70	3.70
Heating	3.08	3.02	3.26	3.34	3.58	3.49	3.80	3.75

Triple

Pair	FAH610H	FAH612H	FAH614H	FAH616H	FAH610S	FAH612S	FAH614S	FAH616S
Cooling	3.48	3.22	3.48	3.56	3.51	3.56	3.56	3.56
Heating	3.49	3.27	3.58	3.62	3.62	3.62	3.62	3.62

Double

Pair	FAH610H	FAH612H	FAH614H	FAH616H	FAH610S	FAH612S	FAH614S	FAH616S
Cooling	3.15	3.16	3.48	3.51	3.51	3.51	3.51	3.51
Heating	2.86	2.71	3.29	3.46	3.56	3.56	3.56	3.56

Double twin

Pair	FAH610H	FAH612H	FAH614H	FAH616H	FAH610S	FAH612S	FAH614S	FAH616S
Cooling	2.64	3.06	3.36	3.38	3.50	3.58	3.58	3.58

3D125182B

RZAG125NV1

RZAG125NY1

Performance characteristics for ·EDP· room

Indoor	Outdoor temperature [°C DB]																																					
	-20		-15		-10		-5		0		5		10		15		20		25		30		35		40													
RH [%]	TCWB	TCDB	TC	SHC	CPI	TC	SHC	CPI	TC	SHC	CPI	TC	SHC	CPI	TC	SHC	CPI	TC	SHC	CPI	TC	SHC	CPI	TC	SHC	CPI												
41.8	11	18	7.49	7.49	0.32	7.49	7.49	0.33	7.49	7.49	0.34	7.49	7.49	0.35	7.49	7.49	0.36	7.49	7.49	0.38	10.25	9.60	0.98	9.71	9.28	1.08	9.17	8.94	1.18	8.69	8.60	1.27						
57.0	13	18	9.34	7.60	0.41	9.34	7.60	0.42	9.34	7.60	0.43	9.34	7.60	0.44	9.34	7.60	0.45	9.34	7.60	0.45	9.34	7.60	0.45	11.91	9.22	0.99	11.41	8.92	1.09	10.91	8.61	1.19	10.37	8.28	1.28			
31.4	11	11	7.49	7.49	0.32	7.49	7.49	0.33	7.49	7.49	0.34	7.49	7.49	0.35	7.49	7.49	0.36	7.49	7.49	0.38	10.25	10.25	0.98	9.71	9.71	1.08	9.17	9.17	1.18	8.69	8.69	1.27						
44.9	13	20	9.34	8.65	0.41	9.34	8.65	0.42	9.34	8.65	0.43	9.34	8.65	0.44	9.34	8.65	0.45	9.34	8.65	0.45	11.91	10.27	0.99	11.41	9.96	1.09	10.91	9.64	1.19	10.37	9.31	1.28						
52.0	14	24	10.27	8.56	0.46	10.27	8.56	0.46	10.27	8.56	0.47	10.27	8.56	0.49	10.27	8.56	0.49	10.27	8.56	0.49	12.88	10.16	0.99	12.54	10.00	1.09	12.21	9.83	1.19	11.87	9.55	1.29						
22.9	11	11	7.49	7.49	0.32	7.49	7.49	0.33	7.49	7.49	0.34	7.49	7.49	0.35	7.49	7.49	0.36	7.49	7.49	0.38	10.25	10.25	0.98	9.71	9.71	1.08	9.17	9.17	1.18	8.69	8.69	1.27						
34.8	13	22	9.34	9.34	0.41	9.34	9.34	0.42	9.34	9.34	0.43	9.34	9.34	0.44	9.34	9.34	0.45	9.34	9.34	0.45	11.91	11.91	0.99	11.41	11.41	1.09	10.91	10.91	1.19	10.37	10.37	1.28						
47.6	15	22	11.20	9.34	0.51	11.20	9.34	0.52	11.20	9.34	0.53	11.20	9.34	0.55	11.20	9.34	0.55	11.20	9.34	0.55	14.51	11.06	0.99	13.36	10.78	1.09	12.88	10.49	1.20	12.41	10.20	1.29						
54.3	16	24	12.12	9.00	0.55	12.12	9.00	0.57	12.12	9.00	0.58	12.12	9.00	0.59	12.12	9.00	0.59	12.12	9.00	0.59	14.51	10.10	1.00	13.98	9.89	1.10	13.52	9.67	1.20	12.98	9.35	1.30						
21.2	12	12	8.42	8.42	0.37	8.42	8.42	0.37	8.42	8.42	0.38	8.42	8.42	0.39	8.42	8.42	0.41	8.42	8.42	0.41	8.42	8.42	0.41	8.42	8.42	0.41	8.42	8.42	0.41	8.42	8.42	0.41	8.42	8.42	0.41			
32.1	14	24	10.27	10.27	0.46	10.27	10.27	0.47	10.27	10.27	0.47	10.27	10.27	0.49	10.27	10.27	0.49	10.27	10.27	0.49	12.88	12.88	0.99	12.54	12.54	1.09	12.21	12.21	1.19	11.87	11.87	1.29						
43.8	16	24	12.12	10.35	0.55	12.12	10.35	0.57	12.12	10.35	0.58	12.12	10.35	0.59	12.12	10.35	0.59	12.12	10.35	0.59	14.51	11.71	1.00	13.98	11.44	1.10	13.52	11.21	1.20	12.98	10.90	1.30						
50.0	17	24	12.47	9.38	0.56	12.47	9.38	0.57	12.47	9.38	0.58	12.47	9.38	0.59	12.47	9.38	0.60	12.47	9.38	0.59	14.51	11.36	1.00	14.54	11.02	1.10	13.89	10.66	1.20	13.24	10.25	1.31						
21.5	14	14	10.27	10.27	0.46	10.27	10.27	0.47	10.27	10.27	0.47	10.27	10.27	0.49	10.27	10.27	0.49	10.27	10.27	0.49	12.88	12.88	0.99	12.54	12.54	1.09	12.21	12.21	1.19	11.87	11.87	1.29						
26.3	15	27	11.20	11.20	0.50	11.20	11.20	0.51	11.20	11.20	0.52	11.20	11.20	0.53	11.20	11.20	0.55	11.20	11.20	0.55	14.51	12.10	0.99	14.51	11.83	1.09	14.51	11.83	1.09	13.36	13.36	1.09	12.88	12.88	1.20	12.41	12.41	1.29
31.3	16	27	12.12	12.12	0.55	12.12	12.12	0.55	12.12	12.12	0.57	12.12	12.12	0.58	12.12	12.12	0.59	12.12	12.12	0.59	14.51	12.12	1.00	14.51	12.12	1.00	14.51	12.12	1.00	13.52	13.52	1.20	12.98	12.98	1.30			

Symbols
TC: Maximum total cooling capacity [kW]
SHC: Sensible heat capacity [kW]
CPI: Coefficient of the power input
PI: Power input [kW]
compressor + indoor and outdoor fan motors
RH: Relative humidity [%]

- The ratings shown are net capacities which include a deduction for indoor fan motor heat.
- The capacities are based on the following conditions:
Outdoor air: 85% RH
Corresponding refrigerant piping length: -5.0 m
Level difference: 0 m
- For ·EDP· applications, it is recommended to use outdoor unit setting 2-57-2.
- CPI is a percentage value compared to the rated value which is 1.00.
- The error rate for this value is less than -5% and depends on the indoor unit type.
- The rated power input for each model is mentioned in the table below.

Pair

Pair	FAHG140H	FAHG140B	FVA140A	FVA140A	FBA140A
Cooling	3.09	3.07	3.17	3.05	2.99

Twin

Pair	FAHG71Hx2	FAHG71Bx2	FHA71Ax2	FUA71Ax2	FAA71Bx2	FBA71Ax2
Cooling	2.57	2.79	2.68	2.69	2.88	2.64

Triple

Pair	FAHG50Bx3	FHA50Ax3	FFA50Ax3	FDXM50Fx3	FBA50Ax3
Cooling	2.57	2.79	2.97	2.36	2.74

Double

Pair	FAHG35Bx4	FHA35Ax4	FFA35Ax4	FDXM35Fx4	FBA35Ax4
Cooling	2.51	2.45	2.71	2.55	2.96

3D125186A

6 Capacity tables

6 - 1 Cooling/Heating Capacity Tables

RZAG140NV1 RZAG140NY1

Cooling

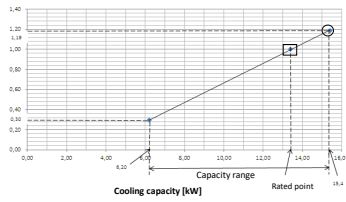

Heating

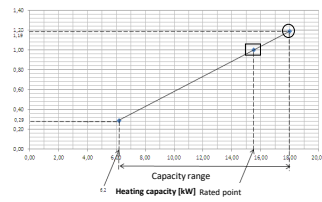

Symbols

- AFR: Air flow rate [m³/min]
- BF: Bypass factor
- EWB: Entering wet-bulb temperature [°C WB]
- EDB: Entering dry-bulb temperature [°C DB]
- TC: Maximum total cooling/heating capacity [kW]
- SHC: Sensible heat capacity [kW]
- CPI: Coefficient of the power input
- PI: Power input [kW]
compressor + indoor and outdoor fan motors

Notes

- The ratings shown are net capacities which include a correction for indoor fan motor heat.
- = Maximum at standard conditions
 - = Rated capacity and rated coefficient of the power input
 - The maximum capacity is not guaranteed except at standard conditions.
- SHC is based on indoor units: EWB + EDB.
SHC for other dry-bulb temperatures = SHC + SHC*.
SHC* = SHC correction for other dry-bulb temperatures
= 0.02 × AFR (m³/min) × (1-BF) × (DB* - EDB)
- The capacities are based on the following conditions:
Outdoor air: 85% RH
However, the outdoor ambient condition of the rated capacity during heating operation is 7°C DB / 6°C WB.
Corresponding refrigerant piping length: 5.0 m
Level difference: 0 m
- CPI is a percentage value compared to the rated value which is 1.00.
- The error rate for this value is less than 5% and depends on the indoor unit type.
- The heating performance takes into account the drop that occurs during defrost operation.
- The air flow rate and bypass factor are mentioned in the table.

Pair	FCAG140H	FCAG140B	FVA140A	FHA140A	FBA140A		
AFR (BF)	33.5 (0.15)	26.0 (0.23)	30.0 (0.18)	34.0 (0.17)	34.0 (0.06)		
Twin	FCAG71H X 2	FCAG71B X 2	FAA71B X 2	FHA71A X 2	FUA71A X 2	FBA71A X 2	FVA71A X 2
AFR (BF)	21.2 x 2 (0.20 x 2)	15.3 x 2 (0.14 x 2)	18.0 x 2 (0.16 x 2)	20.5 x 2 (0.13 x 2)	23.0 x 2 (0.24 x 2)	18.0 x 2 (0.13 x 2)	18.0 x 2 (0.16 x 2)
Triple	FCAG50B X 3	FHA50A X 3	FPA50A X 3	FDM50F X 3	FBA50A X 3	FNA50A X 3	
AFR (BF)	12.6 x 3 (0.22 x 3)	15.0 x 3 (0.16 x 3)	12.0 x 3 (0.16 x 3)	15.8 x 3 (0.11 x 3)	15.0 x 3 (0.13 x 3)	16.0 x 3 (0.11 x 3)	
Double twin	FCAG35B X 4	FHA35A X 4	FPA35A X 4	FDM35F X 4	FBA35A X 4	FNA35A X 4	
AFR (BF)	12.5 x 4 (0.40 x 4)	14.0 x 4 (0.20 x 4)	10.0 x 4 (0.25 x 4)	8.7 x 4 (0.17 x 4)	15.0 x 4 (0.08 x 4)	8.7 x 4 (0.17 x 4)	

Indoor		Outdoor temperature [°C DB]													
		25			30			35			40				
TC	SHC	CPI	TC	SHC	CPI	TC	SHC	CPI	TC	SHC	CPI	TC	SHC	CPI	
16.0	22	15.50	10.47	0.98	14.93	10.25	1.08	14.44	10.03	1.18	13.86	9.69	1.28		
18.0	25	16.17	10.55	0.98	15.62	10.21	1.09	15.11	10.01	1.19	14.52	9.71	1.30		
19.0	27	16.56	10.43	0.99	15.96	10.18	1.09	15.40	9.98	1.19	14.83	9.76	1.30		
19.5	27	16.74	10.49	0.99	16.14	10.16	1.10	15.57	10.00	1.19	14.98	9.66	1.30		
22.0	30	17.61	10.37	0.99	17.01	10.16	1.10	16.36	9.83	1.21	15.76	9.60	1.31		
24.0	32	18.38	10.20	1.00	17.72	10.00	1.11	17.04	9.67	1.22	16.43	9.47	1.32		

Indoor		Outdoor temperature [°C WB]												
		-15			-10			0			6			10
TC	SHC	CPI	TC	SHC	CPI	TC	SHC	CPI	TC	SHC	CPI	TC	SHC	CPI
16	11.6	0.91	12.7	0.87	13.6	1.00	13.9	1.03	18.0	1.09	19.4	1.16		
18	11.6	0.96	12.7	1.00	13.6	1.04	13.9	1.07	18.0	1.14	19.4	1.21		
20	11.6	0.99	12.7	1.05	13.5	1.09	13.9	1.11	18.0	1.19	19.4	1.25		
21	11.5	1.00	12.7	1.06	13.5	1.11	13.9	1.13	18.0	1.21	19.4	1.28		
22	11.5	1.02	12.7	1.08	13.5	1.12	13.9	1.16	18.0	1.24	19.4	1.30		
24	11.5	1.07	12.6	1.12	13.5	1.17	13.9	1.20	18.0	1.29	19.4	1.35		

9. The rated power input for each model is mentioned in the table below.

Pair	FCAG140H	FCAG140B	FVA140A	FHA140A	FBA140A		
Cooling	3.64	4.29	4.42	4.31	4.69		
Heating	3.64	4.55	4.48	4.33	4.92		
Twin	FCAG71H X 2	FCAG71B X 2	FAA71B X 2	FHA71A X 2	FUA71A X 2	FBA71A X 2	FVA71A X 2
Cooling	3.67	4.08	4.38	3.83	3.84	4.17	4.38
Heating	3.69	3.69	3.67	3.50	3.28	3.55	3.92
Triple	FCAG50B X 3	FHA50A X 3	FPA50A X 3	FDM50F X 3	FBA50A X 3	FNA50A X 3	
Cooling	3.62	4.06	4.61	3.62	4.12	3.62	
Heating	3.44	3.29	3.87	2.96	3.23	3.03	
Double twin	FCAG35B X 4	FHA35A X 4	FPA35A X 4	FDM35F X 4	FBA35A X 4	FNA35A X 4	
Cooling	3.22	3.57	3.89	3.96	3.46	3.96	
Heating	3.97	2.89	4.19	3.49	4.22	3.53	

3D125183C

RZAG140NV1 RZAG140NY1

Performance characteristics for EDP room

Indoor		Outdoor temperature [°C DB]																																										
		-20			-15			-10			-5			0			5			10			15			20			25			30			35			40						
RH [%]	*CWB	*CDB	TC	SHC	CPI	TC	SHC	CPI	TC	SHC	CPI	TC	SHC	CPI	TC	SHC	CPI	TC	SHC	CPI	TC	SHC	CPI	TC	SHC	CPI	TC	SHC	CPI	TC	SHC	CPI	TC	SHC	CPI	TC	SHC	CPI						
41.8	11	18	8.24	8.24	0.31	8.24	8.24	0.32	8.24	8.24	0.33	8.24	8.24	0.34	8.24	8.24	0.35	8.24	8.24	0.37	8.24	8.24	0.37	8.24	8.24	0.37	8.24	8.24	0.38	8.24	8.24	0.38	10.95	9.96	0.96	10.37	9.62	1.06	9.79	9.27	1.16	9.28	8.92	1.25
57.0	13	20	10.28	10.28	0.40	10.28	10.28	0.41	10.28	10.28	0.42	10.28	10.28	0.43	10.28	10.28	0.45	10.28	10.28	0.45	10.28	10.28	0.44	10.28	10.28	0.44	10.28	10.28	0.44	12.72	9.56	0.97	12.18	9.25	1.07	11.65	8.93	1.17	11.07	8.58	1.26			
31.4	11	18	8.24	8.24	0.31	8.24	8.24	0.32	8.24	8.24	0.33	8.24	8.24	0.34	8.24	8.24	0.35	8.24	8.24	0.37	8.24	8.24	0.37	8.24	8.24	0.37	8.24	8.24	0.38	10.95	10.95	0.96	10.37	10.37	1.06	9.79	9.79	1.16	9.28	9.28	1.25			
44.9	13	20	10.28	9.35	0.40	10.28	9.35	0.41	10.28	9.35	0.42	10.28	9.35	0.43	10.28	9.35	0.45	10.28	9.35	0.45	10.28	9.35	0.44	10.28	9.35	0.44	10.28	9.35	0.44	12.72	10.64	0.97	12.18	10.33	1.07	11.65	10.00	1.17	11.07	9.65	1.26			
52.0	14	21	11.30	9.26	0.45	11.30	9.26	0.45	11.30	9.26	0.47	11.30	9.26	0.48	11.30	9.26	0.49	11.30	9.26	0.49	11.30	9.26	0.49	11.30	9.26	0.47	11.30	9.26	0.47	13.75	10.53	0.97	13.40	10.36	1.07	13.04	10.19	1.17	12.68	9.90	1.27			
22.9	11	18	8.24	8.24	0.31	8.24	8.24	0.32	8.24	8.24	0.33	8.24	8.24	0.34	8.24	8.24	0.35	8.24	8.24	0.37	8.24	8.24	0.37	8.24	8.24	0.37	8.24	8.24	0.38	8.24	8.24	0.38	10.95	10.95	0.96	10.37	10.37	1.06	9.79	9.79	1.16	9.28	9.28	1.25
34.8	13	20	10.28	10.28	0.40	10.28	10.28	0.41	10.28	10.28	0.42	10.28	10.28	0.43	10.28	10.28	0.45	10.28	10.28	0.45	10.28	10.28	0.44	10.28	10.28	0.44	10.28	10.28	0.44	12.72	12.72	0.97	12.18	12.18	1.07	11.65	11.65	1.17	11.07	11.07	1.26			
47.6	15	22	12.32	10.10	0.50	12.32	10.10	0.50	12.32	10.10	0.51	12.32	10.10	0.52	12.32	10.10	0.54	12.32	10.10	0.54	12.32	10.10	0.53	12.32	10.10	0.53	12.32	10.10	0.50	14.77	11.47	0.98	14.26	11.18	1.08	13.76	10.88	1.18	13.25	10.57	1.27			
54.3	16	23	13.33	9.73	0.54	13.33	9.73	0.54	13.33	9.73	0.56	13.33	9.73	0.57	13.33	9.73	0.59	13.33	9.73	0.59	13.33	9.73	0.58	13.33	9.73	0.58	13.33	9.73	0.54	15.50	10.47	0.98	14.93	10.25	1.08	14.44	10.03	1.18	13.86	9.69	1.28			
21.2	12	19	9.26	9.26	0.36	9.26	9.26	0.37	9.26	9.26	0.38	9.26	9.26	0.39	9.26	9.26	0.40	9.26	9.26	0.41	9.26	9.26	0.41	9.26	9.26	0.41	9.26	9.26	0.41	11.83	11.83	0.97	11.28	11.28	1.07	10.72	10.72	1.17	10.17	10.17	1.25			
32.1	14	21	11.30	11.30	0.45	11.30	11.30	0.45	11.30	11.30	0.47	11.30	11.30	0.48	11.30	11.30	0.49	11.30	11.30	0.49	11.30	11.30	0.49	11.30	11.30	0.47	11.30	11.30	0.47	13.75	13.75	0.97	13.40	13.40	1.07	13.04	13.04	1.17	12.68	12.68	1.27			
43.8	16	24	13.33	11.20	0.54	13.33	11.20	0.54	13.33	11.20	0.56	13.33	11.20	0.57	13.33	11.20	0.58	13.33	11.20	0.58	13.33	11.20	0.57	13.33	11.20	0.55	13.33	11.20	0.53	15.50	12.14	0.98	14.93	11.86	1.08	14.44	11.62	1.18	13.86	11.30	1.28			
50.0	17	25	13.72	10.15	0.55	13.72	10.15	0.56	13.72	10.15	0.57	13.72	10.15	0.58	13.72	10.15	0.59	13.72	10.15	0.59	13.72	10.15	0.58	13.72	10.15	0.58	13.72	10.15	0.58	16.23	11.78	0.98	15.53	11.43	1.08	14.83	11.06	1.18	14.14	10.63	1.29			
21.5	14	21	11.30	11.30	0.45	11.30	11.30	0.45	11.30	11.30	0.47	11.30	11.30	0.48	11.30	11.30	0.49	11.30	11.30	0.49	11.30	11.30	0.49	11.30	11.30	0.47	11.30	11.30	0.47	13.75	13.75	0.97	13.40	13.40	1.0									

6 Capacity tables

6 - 2 Capacity Correction Factor

6

RZAG-NV1
RZAG-NY1

Capacity in function of field piping length

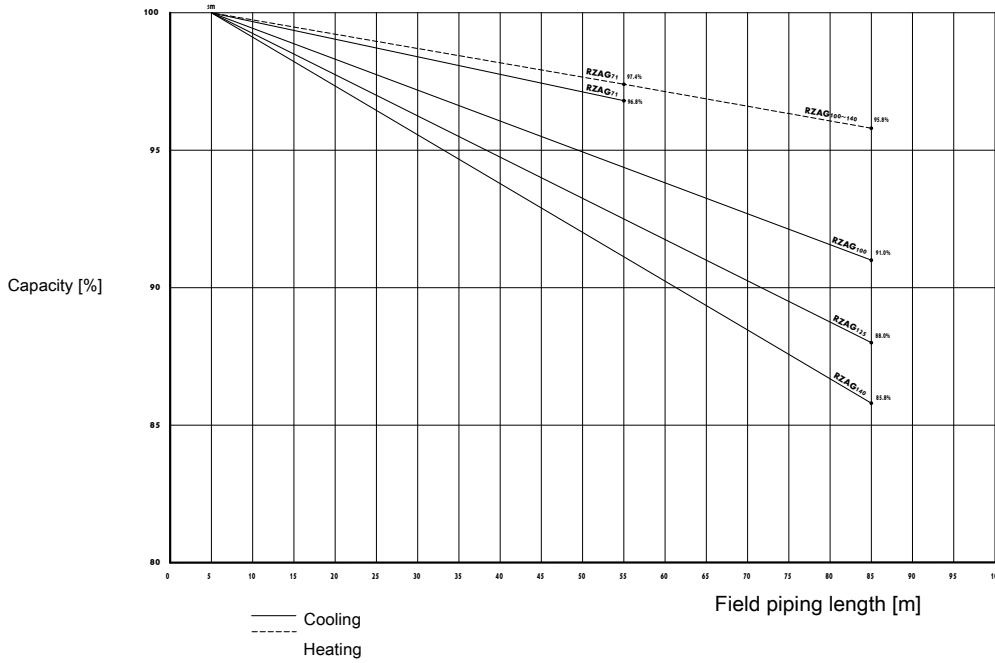

3D112162

7 Dimensional drawings

7 - 1 Dimensional Drawings

RZAG-NV1
RZAG-NY1

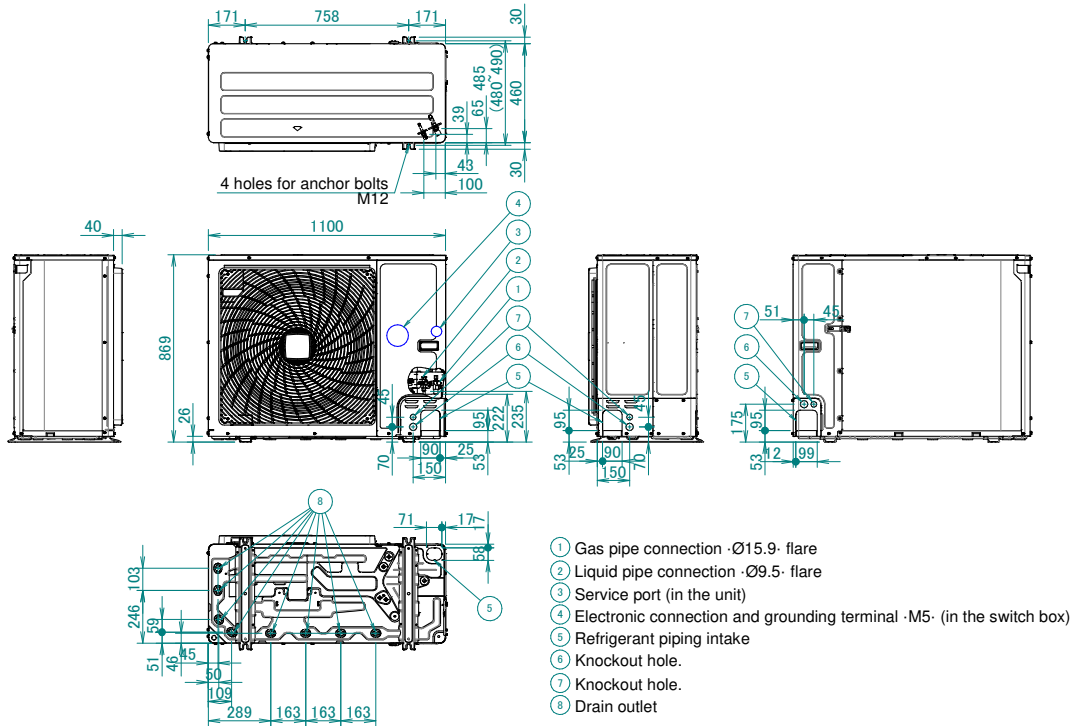

3D120936

8 Centre of gravity

8 - 1 Centre of Gravity

8

RZAG-NV1

RZAG-NY1

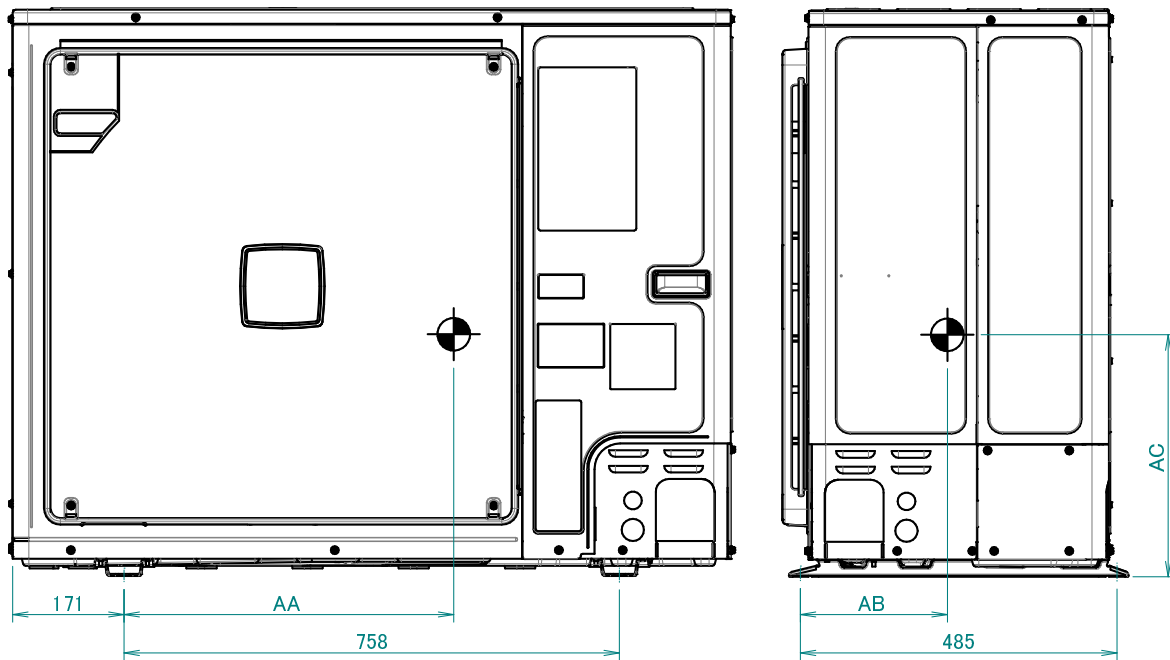

Model	AA	AB	AC
RZAG71N2/7V1B	520.3	238.7	357.8
RZAG71N2/7Y1B	525.9	224.7	359.8
RZAG100N2/7V1B	499.7	239.3	367.6
RZAG100N2/7Y1B	511.2	223.5	362.5
RZAG125/140N2/7V1B	486.3	229.2	371.8
RZAG125/140N2/7Y1B	493.4	215.8	372.2
RXYSA4/5/6A7V1B	530.4	249.9	389.0
RXYSA4/5/6A7Y1B			

4D120933C

9 Piping diagrams

9 - 1 Piping Diagrams

RZAG-NV1
RZAG-NY1

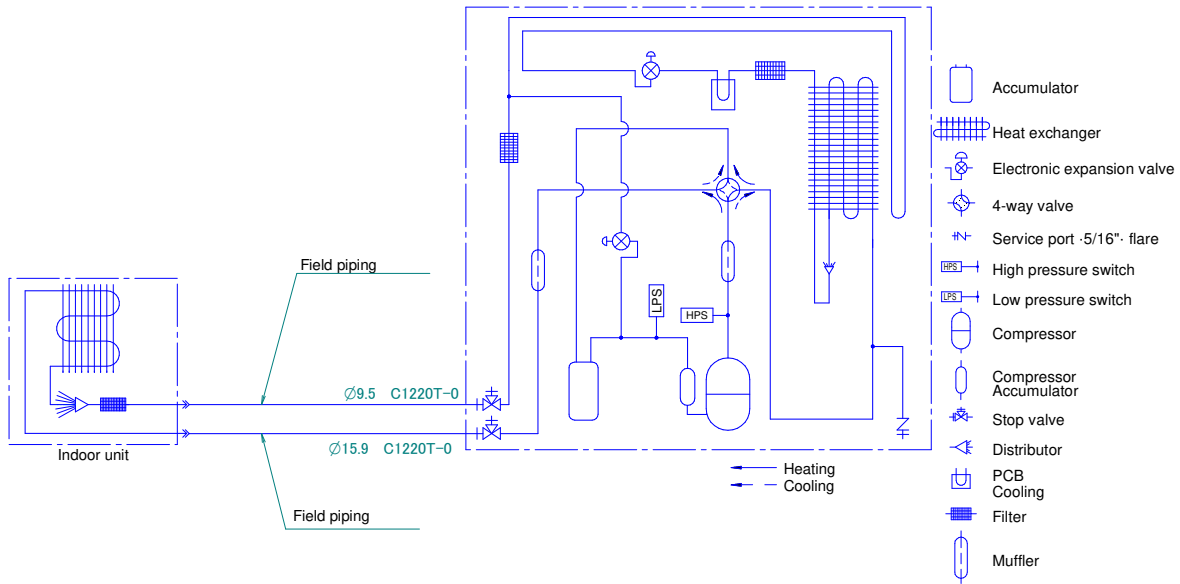

Notes

1. The pipes between the branch and the indoor units should have the same size as the indoor connections.

3D120907

9 Piping diagrams

9 - 2 Piping Diagram Twin Application

9

RZAG-NV1
RZAG-NY1

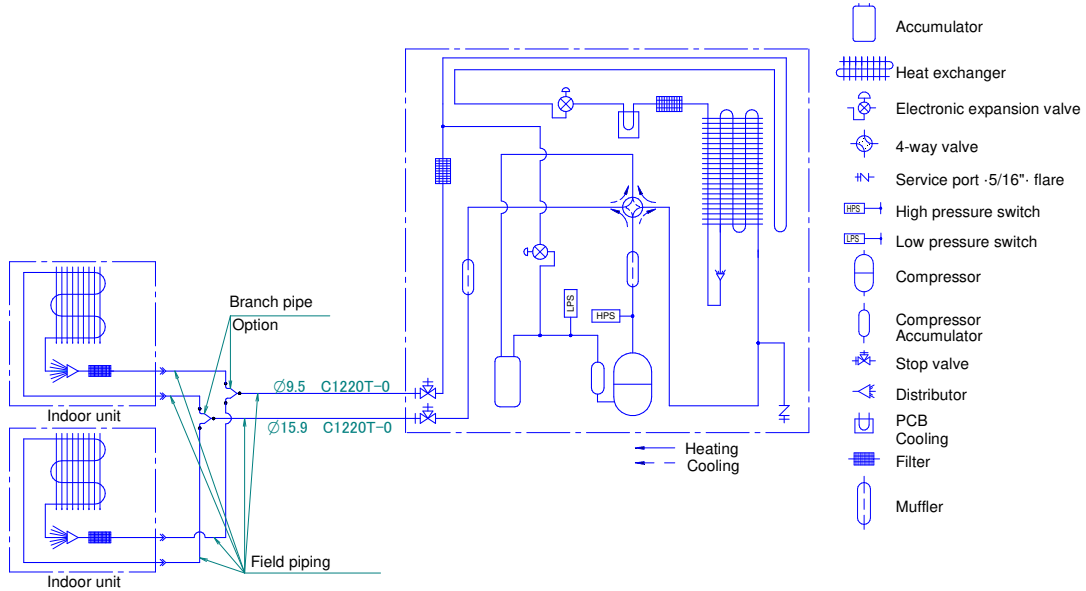

Notes

1. The pipes between the branch and the indoor units should have the same size as the indoor connections.

3D120913

9 Piping diagrams

9 - 3 Piping Diagram Triple Application

RZAG100-140NV1
RZAG100-140NY1

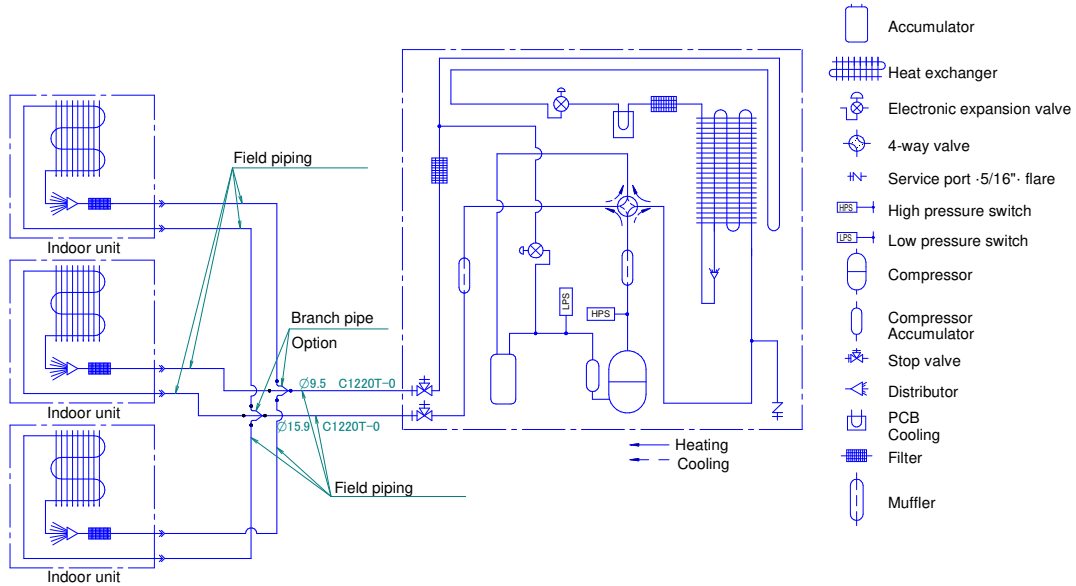

Notes

1. The pipes between the branch and the indoor units should have the same size as the indoor connections.

3D120914

9 Piping diagrams

9 - 4 Piping Diagram Double Twin Application

9

RZAG125-140NV1
RZAG125-140NY1

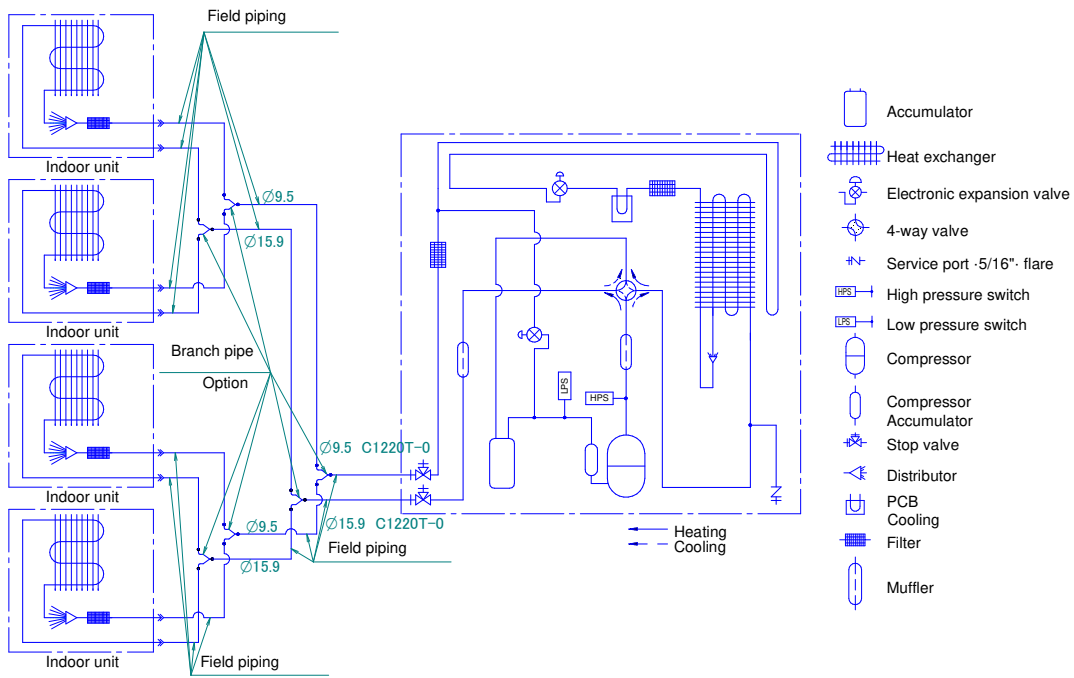

Notes

1. The pipes between the branch and the indoor units should have the same size as the indoor connections.

3D120915

10 Wiring diagrams

10 - 1 Wiring Diagrams - Single Phase

RZAG-NY1

(1) Connection diagram

(2) Layout

OUTDOOR

INDOOR

Front

Back

Position of compressor terminal

(3) NOTES

- : Connection
- : Earth wiring
- : Field supply
- : Option
- : switch box
- : PCB
- : Wiring depending on model
- : Protective earth
- : Field wire

(4) LEGEND

Part n°	Description
A1P	Printed circuit board (main)
A2P	Printed circuit board (noise filter)
A3P	* Printed circuit board (demand)
BS1-3 (A1P)	Push-button switch
C1-C5 (A1P)	Capacitor
DS1 (A1P, A3P)	Dipswitch
E1H	* Bottom plate heater
F1U (A2P)	Fuse T 6,3 A 250 V
F4U, F5U (A2P)	Fuse T 30 A 500 V
F6U (A1P)	Fuse T 6,3 A 250 V
F7U (A1P)	Fuse T 5 A 250 V
F8U, F9U	* Fuse F 1 A 250 V
HAP (A1P)	Light-emitting diode (service monitor is green)
K1M, K3M (A1P)	Magnetic contactor
K1R (A1P)	Magnetic relay (Y1S)
K4R (A1P)	Magnetic relay (E1H)
K10R	Magnetic relay
K13R-K15R (A1P)	Magnetic relay
L1R	Reactor
M1C	Compressor motor
M1F	Fan motor
PS (A1P)	Switching power supply
Q1DI	Earth leakage circuit breaker (30mA)

Part n°	Description
Q1E	Overload protection
R1-R6, R8 (A1P)	Resistor
R1T	Thermistor (air)
R2T	Thermistor (discharge)
R3T	Thermistor (suction)
R4T	Thermistor (heat exchanger)
R5T	Thermistor (heat exchanger middle)
R6T	Thermistor (liquid)
R7T	Thermistor (fin)
RC (A1P)	Signal receiver circuit
S1PH	High pressure switch
S1PL	Low pressure switch
SEG1-SEG3 (A1P)	7-segment display
TC (A1P)	Signal transmission circuit
V1D, V2D (A1P)	Diode
V1R, V2R (A1P)	Diode module
V3R, V4R (A1P)	IGBT power module
X1M	Terminal strip
Y1E, Y3E	Electronic expansion valve
Y1S	Solenoid valve (4-way valve)
Z1C-Z6C	Noise filter (ferrite core)
Z1F-Z4F (A1P-A2P)	Noise filter
L*A, L*B, NA, NB	Connector
E*, U, V, W, X*A (A1P, A2P)	Connector

* : optional
: field supply

NOTES

- Refer to the wiring diagram sticker (on the back of the front plate) for how to use the BS1-BS3 and DS1 switches.
- When operating, do not short-circuit protection device(s) S1PH, S1PL and Q1E.
- Refer to the combination table and the option manual for how to connect the wiring to X28A and X801M.
- Colours: BLK:black; RED:red; BLU:blue; WHT:white; GRN:green

4D120911

11 Sound data

11 - 1 Sound Power Spectrum

11

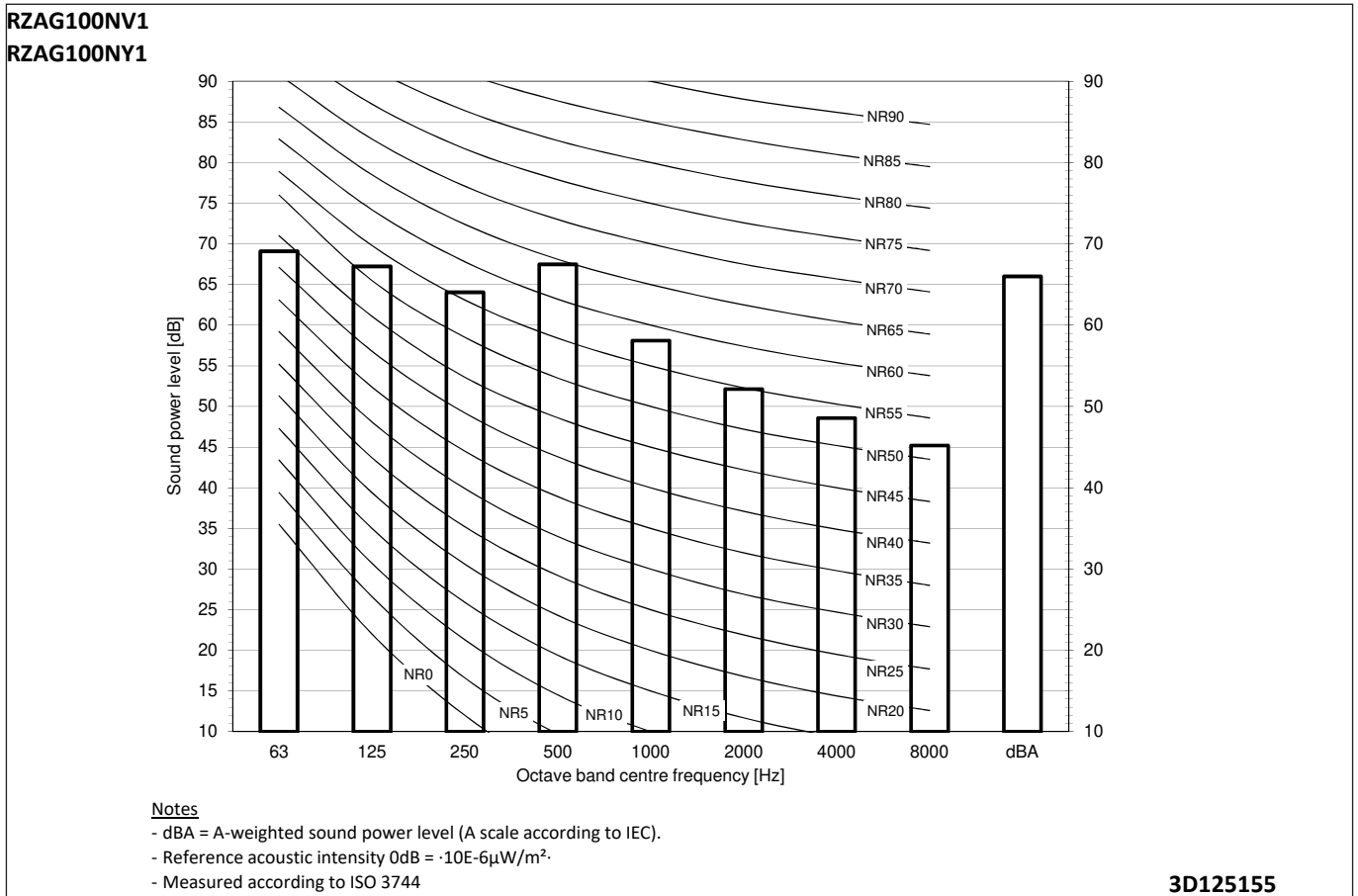
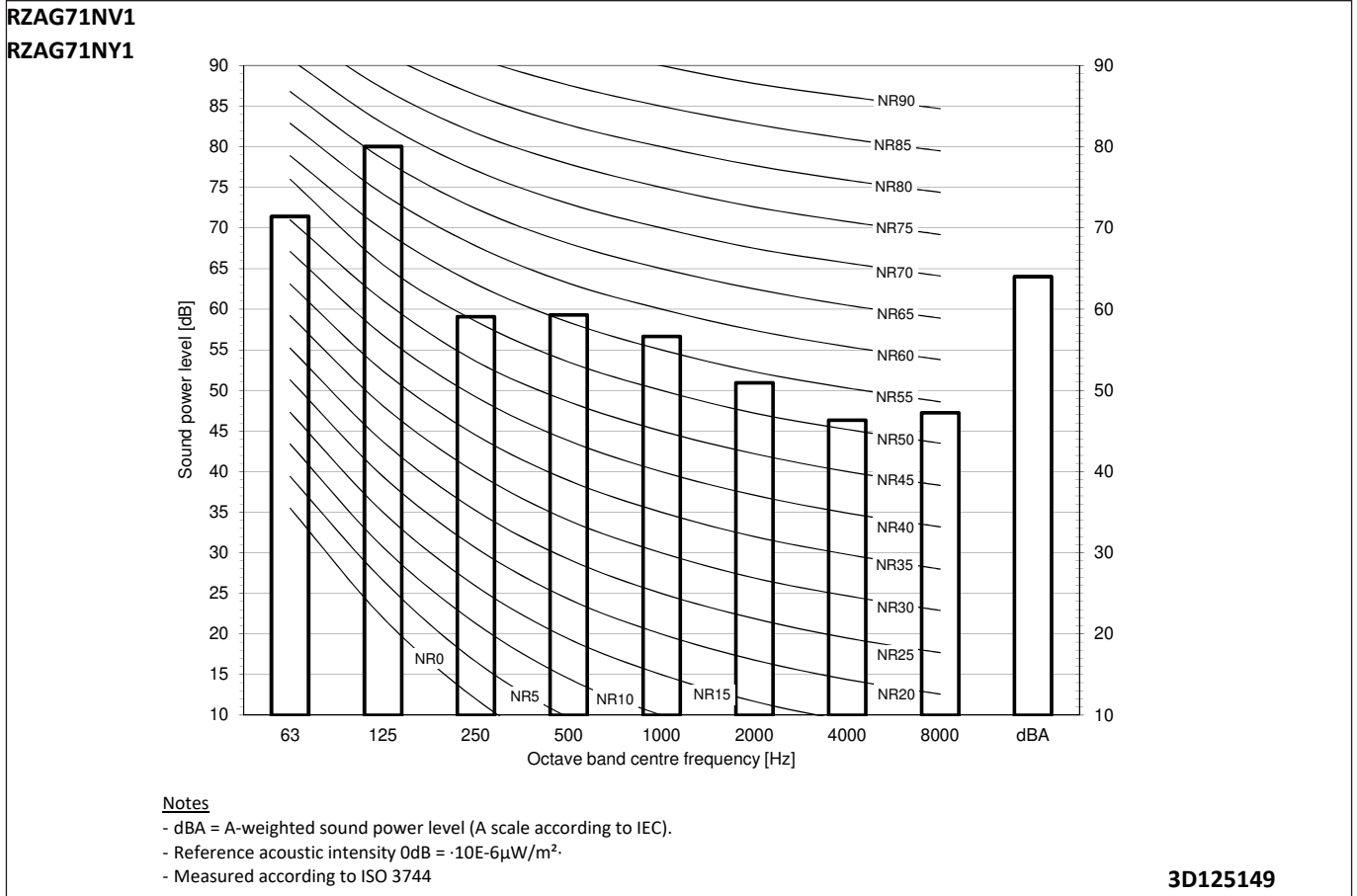

11 Sound data

11 - 1 Sound Power Spectrum

RZAG125NV1
RZAG125NY1

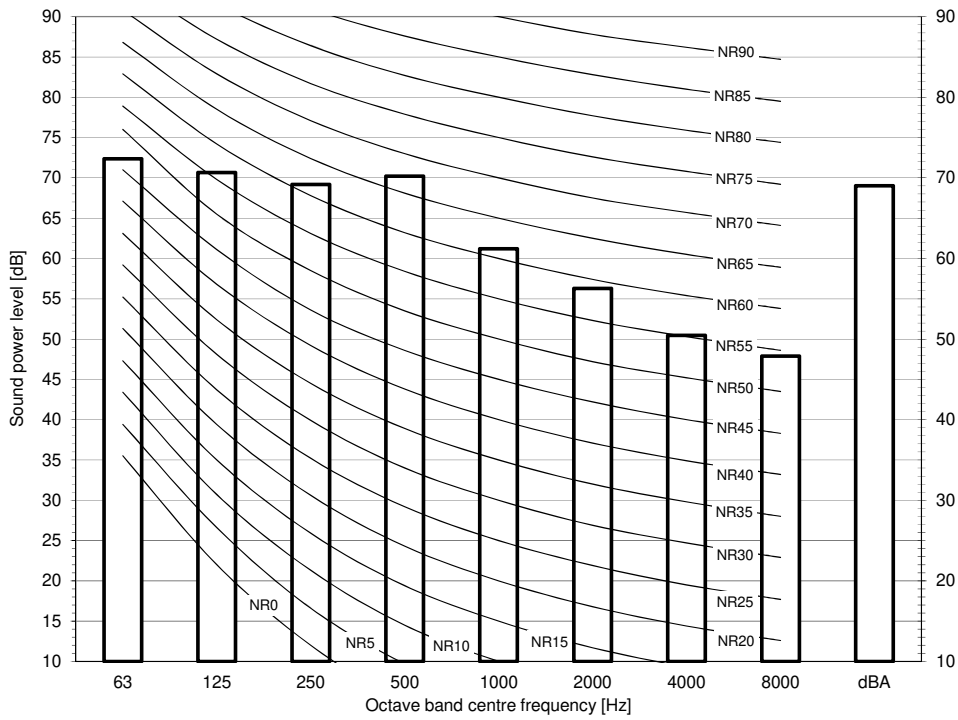

Notes

- dBA = A-weighted sound power level (A scale according to IEC).
- Reference acoustic intensity 0dB = $\cdot 10E-6\mu W/m^2$.
- Measured according to ISO 3744

3D125161

RZAG140NV1
RZAG140NY1

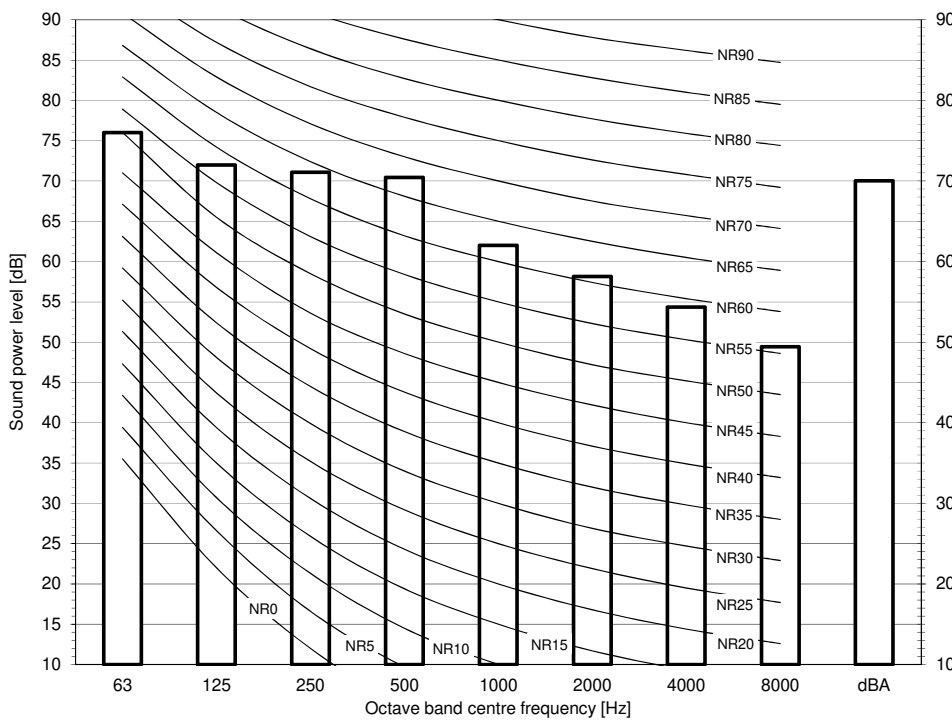

Notes

- dBA = A-weighted sound power level (A scale according to IEC).
- Reference acoustic intensity 0dB = $\cdot 10E-6\mu W/m^2$.
- Measured according to ISO 3744

3D125167

11 Sound data

11 - 2 Sound Pressure Spectrum - Cooling

11

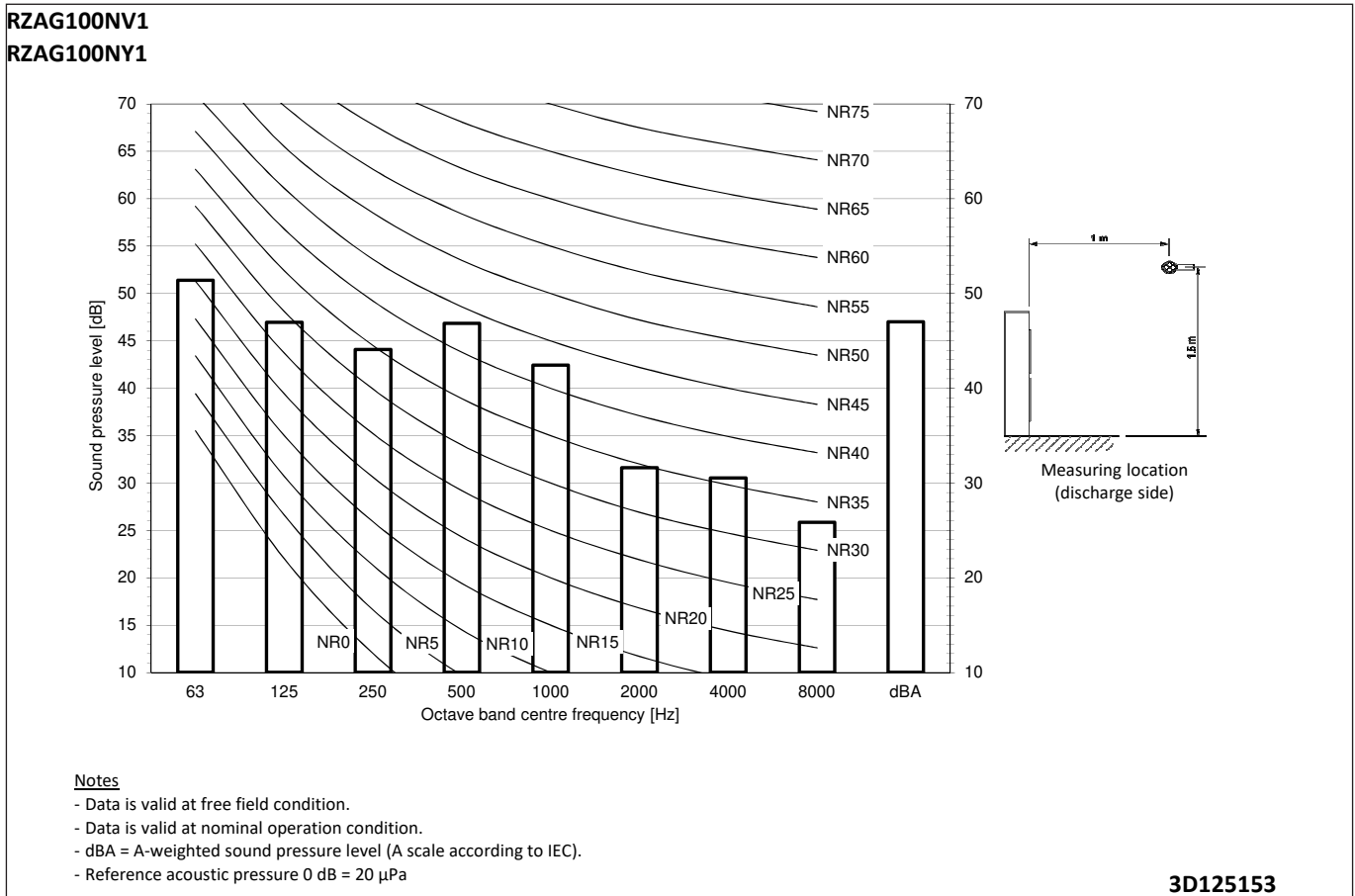
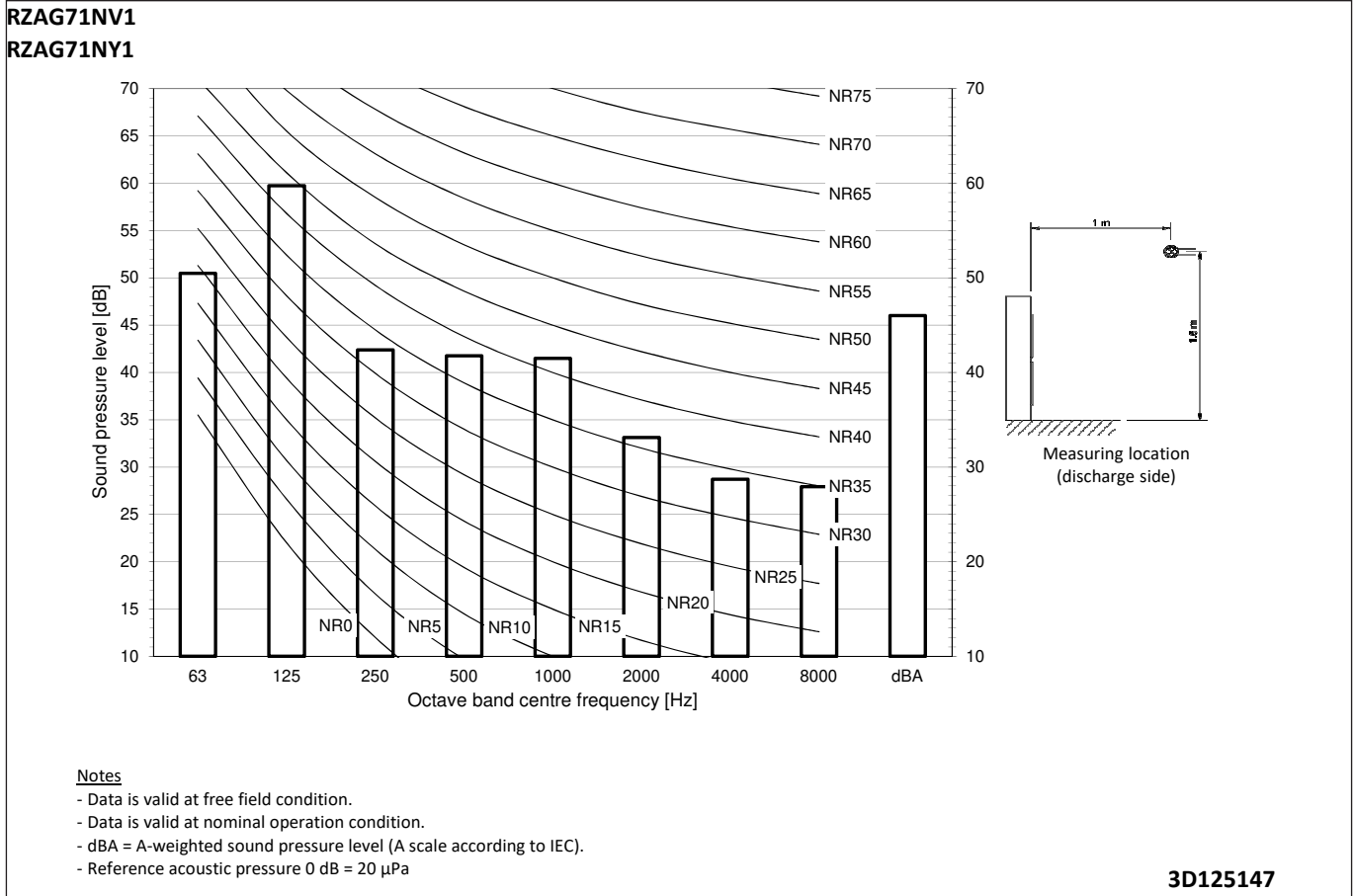

11 Sound data

11 - 2 Sound Pressure Spectrum - Cooling

RZAG125NV1
RZAG125NY1

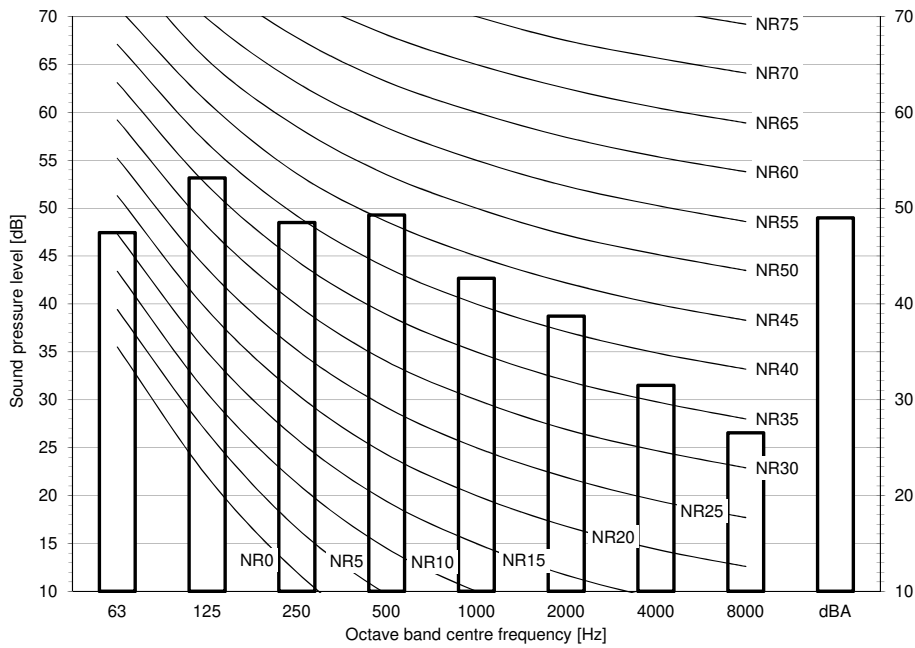

Notes

- Data is valid at free field condition.
- Data is valid at nominal operation condition.
- dBA = A-weighted sound pressure level (A scale according to IEC).
- Reference acoustic pressure 0 dB = 20 μPa

3D125159

RZAG140NV1
RZAG140NY1

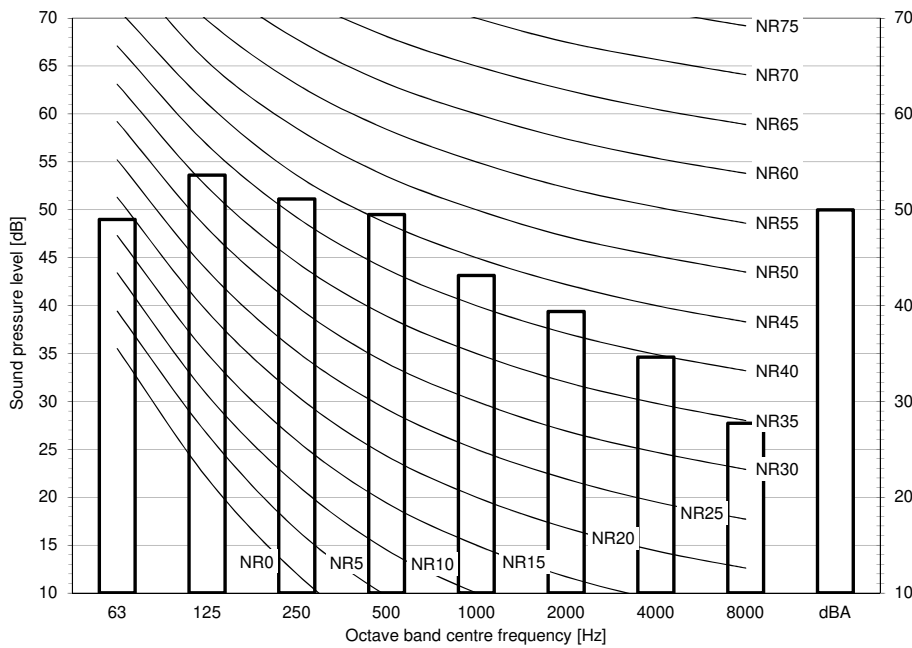

Notes

- Data is valid at free field condition.
- Data is valid at nominal operation condition.
- dBA = A-weighted sound pressure level (A scale according to IEC).
- Reference acoustic pressure 0 dB = 20 μPa

3D125165

11 Sound data

11 - 3 Sound Pressure Spectrum - Heating

11

RZAG71NV1
RZAG71NY1

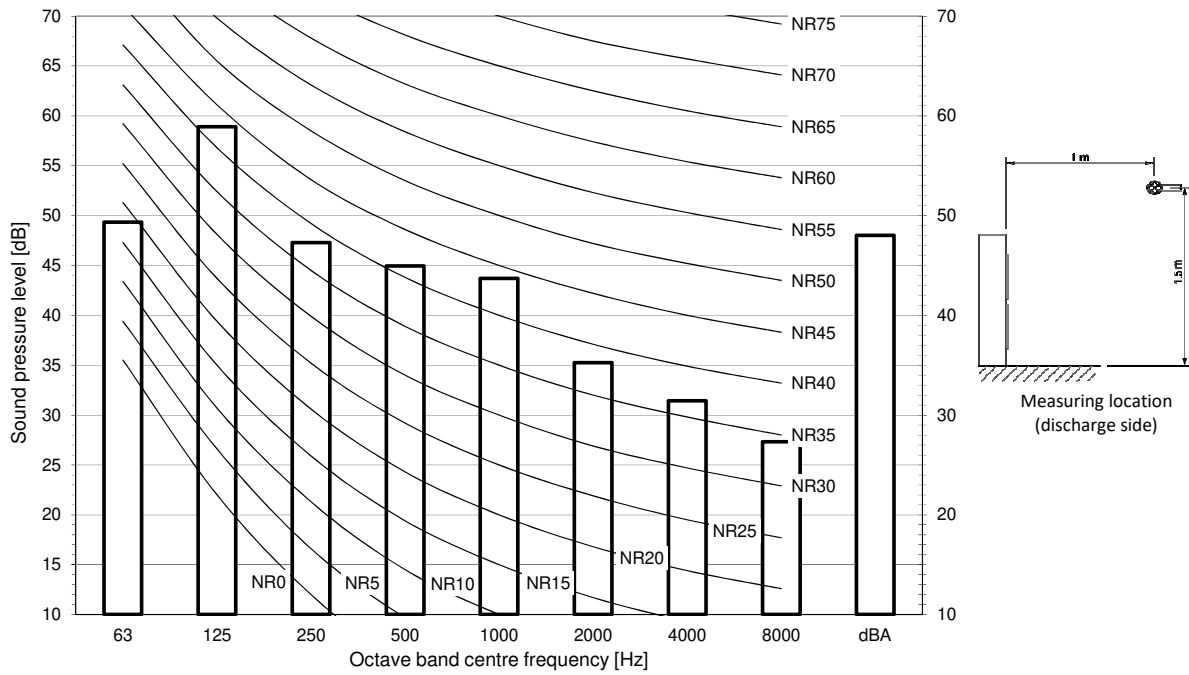

Notes

- Data is valid at free field condition.
- Data is valid at nominal operation condition.
- dBA = A-weighted sound pressure level (A scale according to IEC).
- Reference acoustic pressure 0 dB = 20 μPa

3D125148

RZAG100NV1
RZAG100NY1

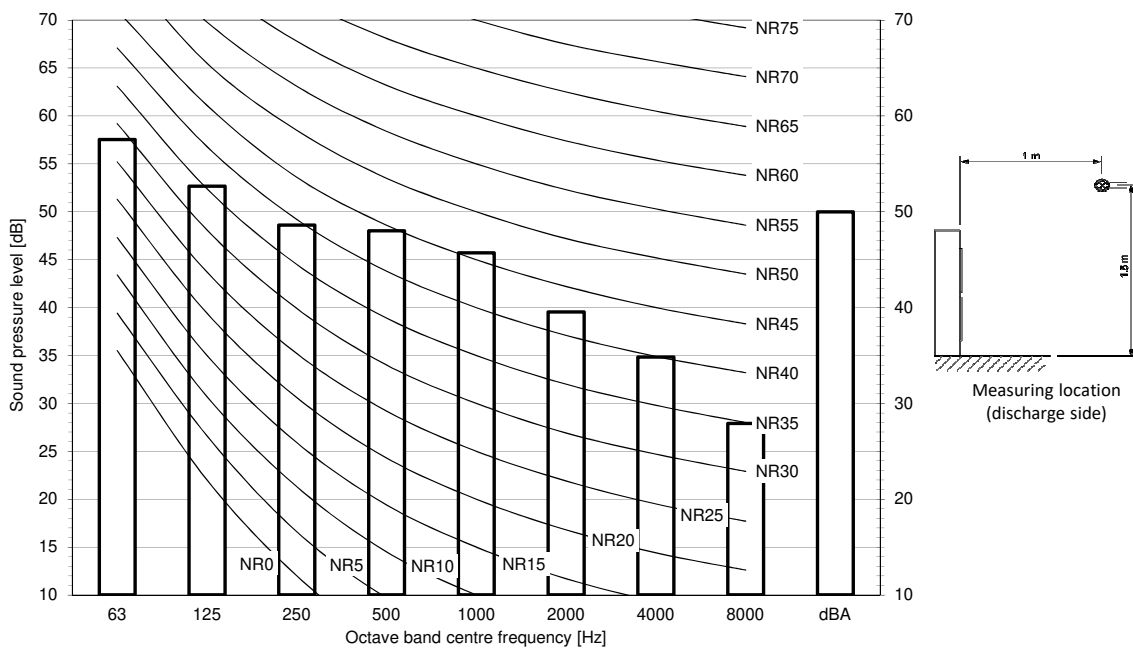

Notes

- Data is valid at free field condition.
- Data is valid at nominal operation condition.
- dBA = A-weighted sound pressure level (A scale according to IEC).
- Reference acoustic pressure 0 dB = 20 μPa

3D125154

11 Sound data

11 - 3 Sound Pressure Spectrum - Heating

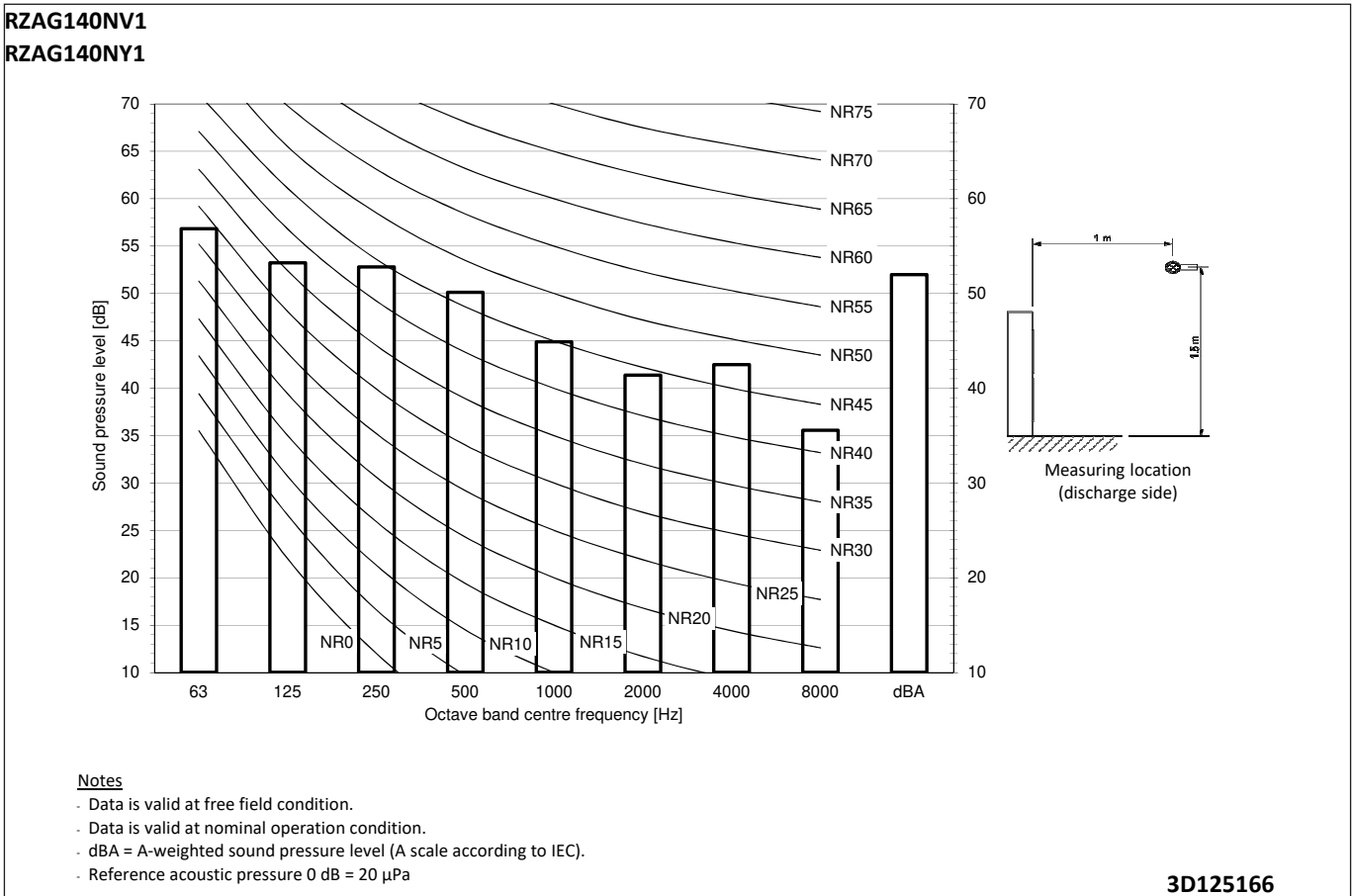
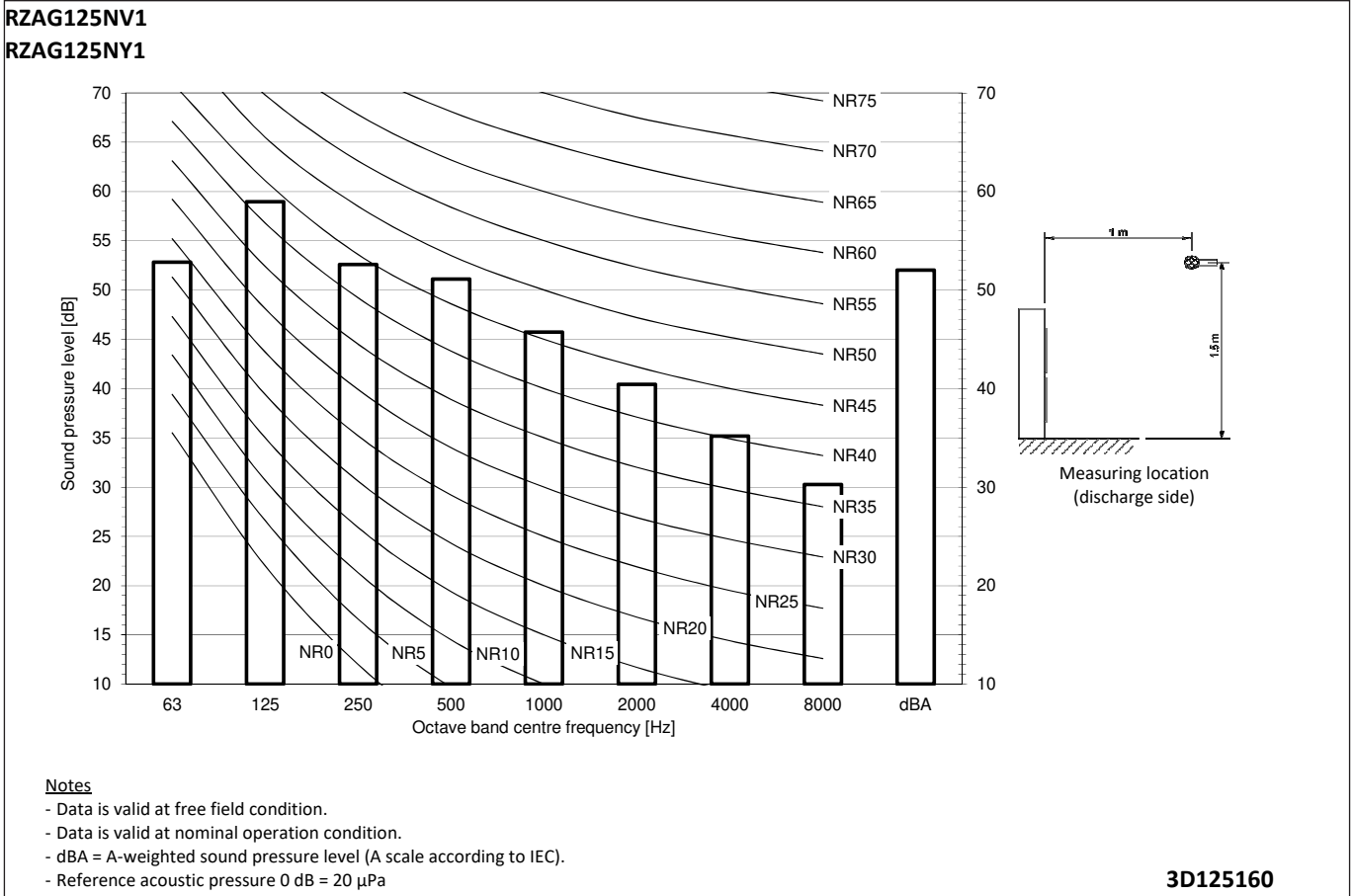

11 Sound data

11 - 4 Sound Pressure Spectrum Quiet Mode Level 1

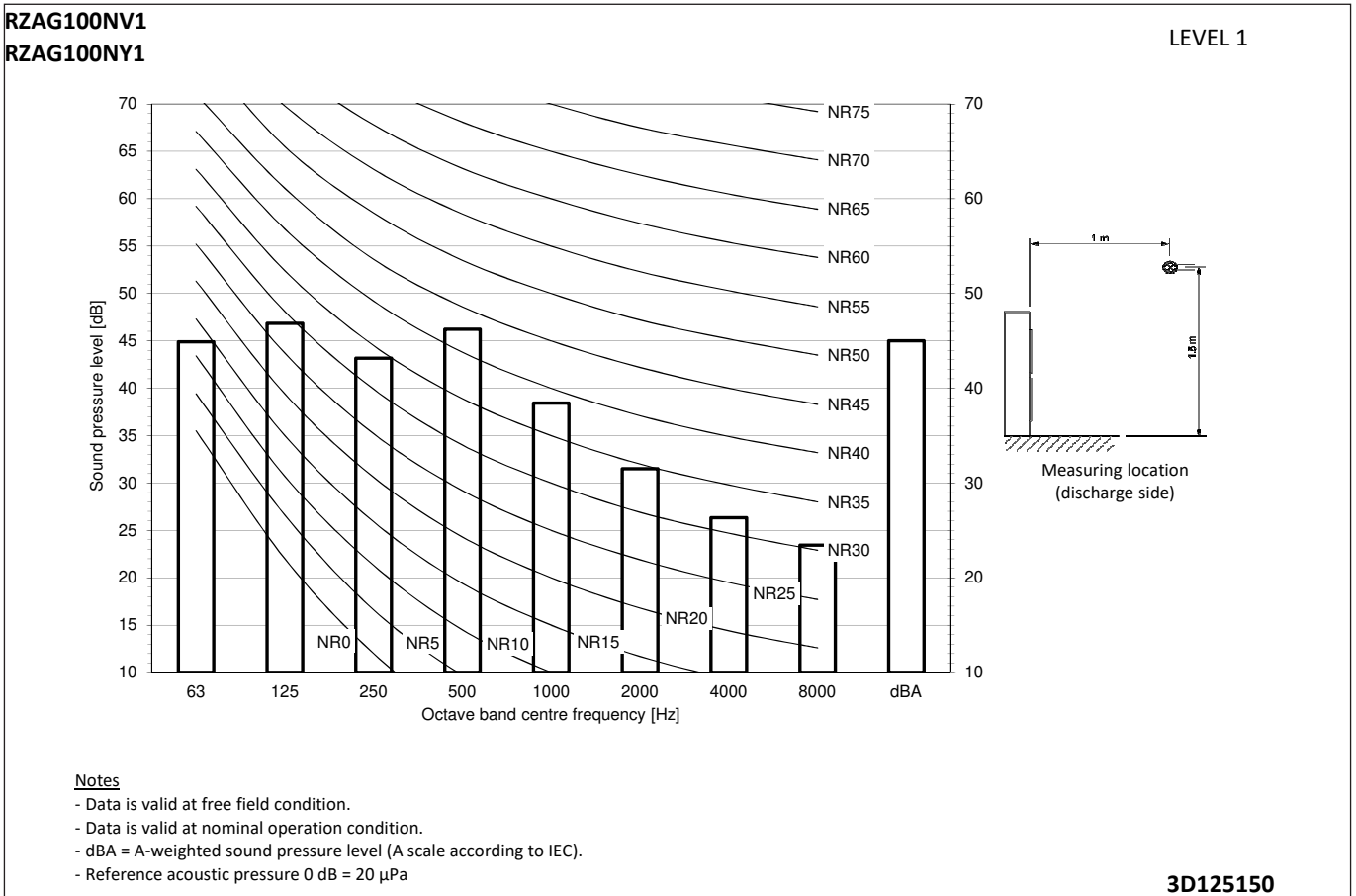
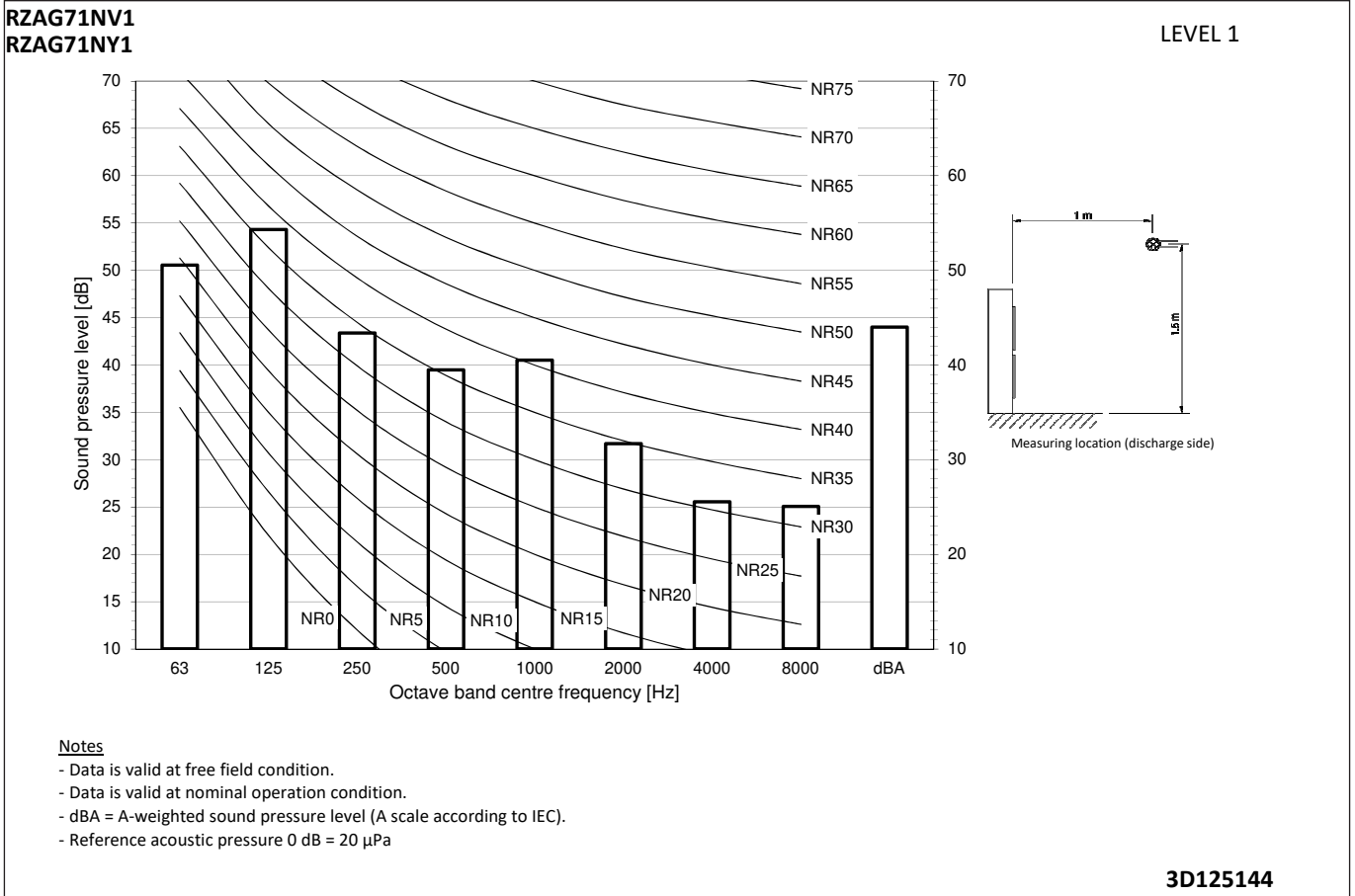

11 Sound data

11 - 4 Sound Pressure Spectrum Quiet Mode Level 1

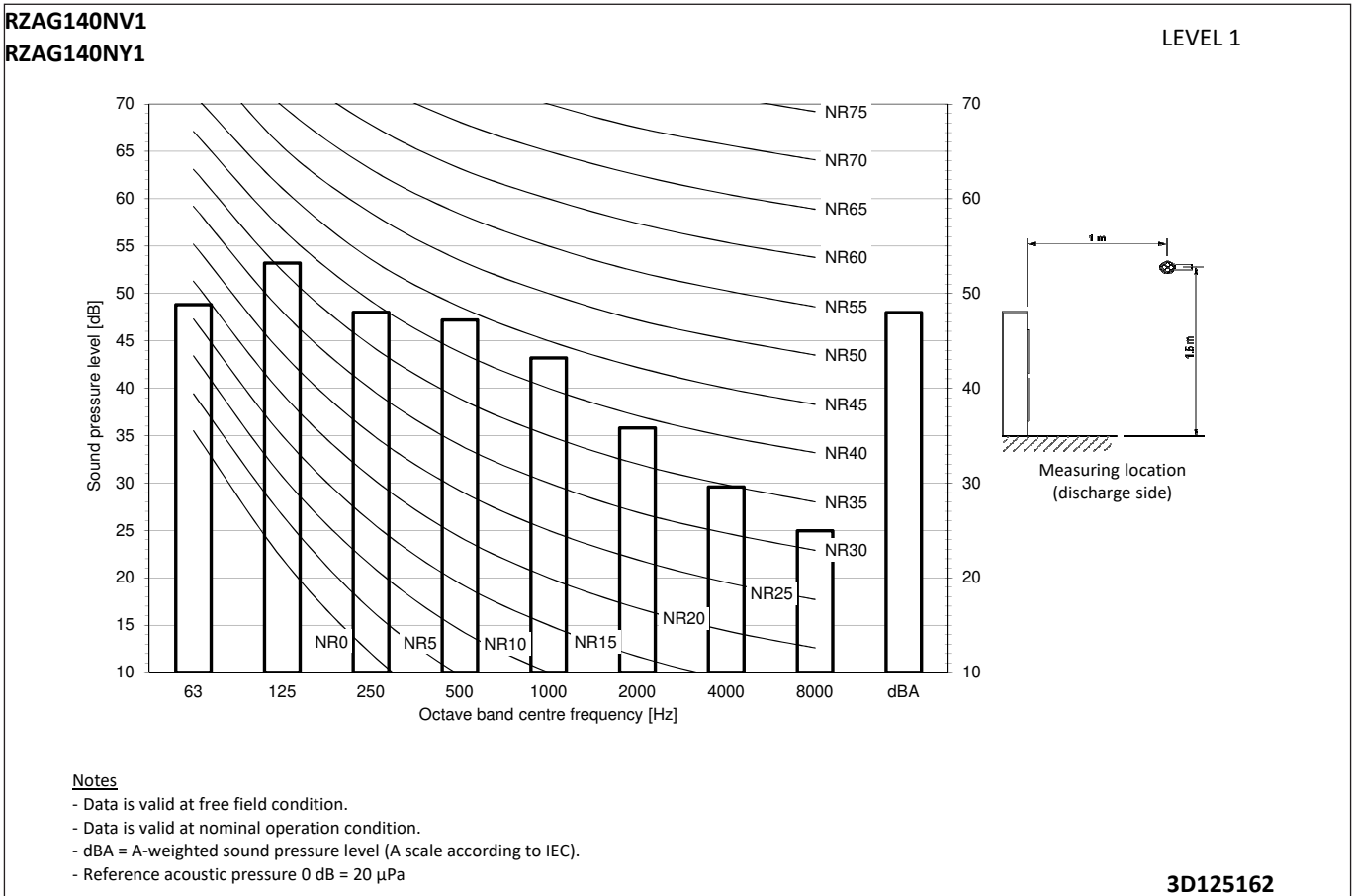
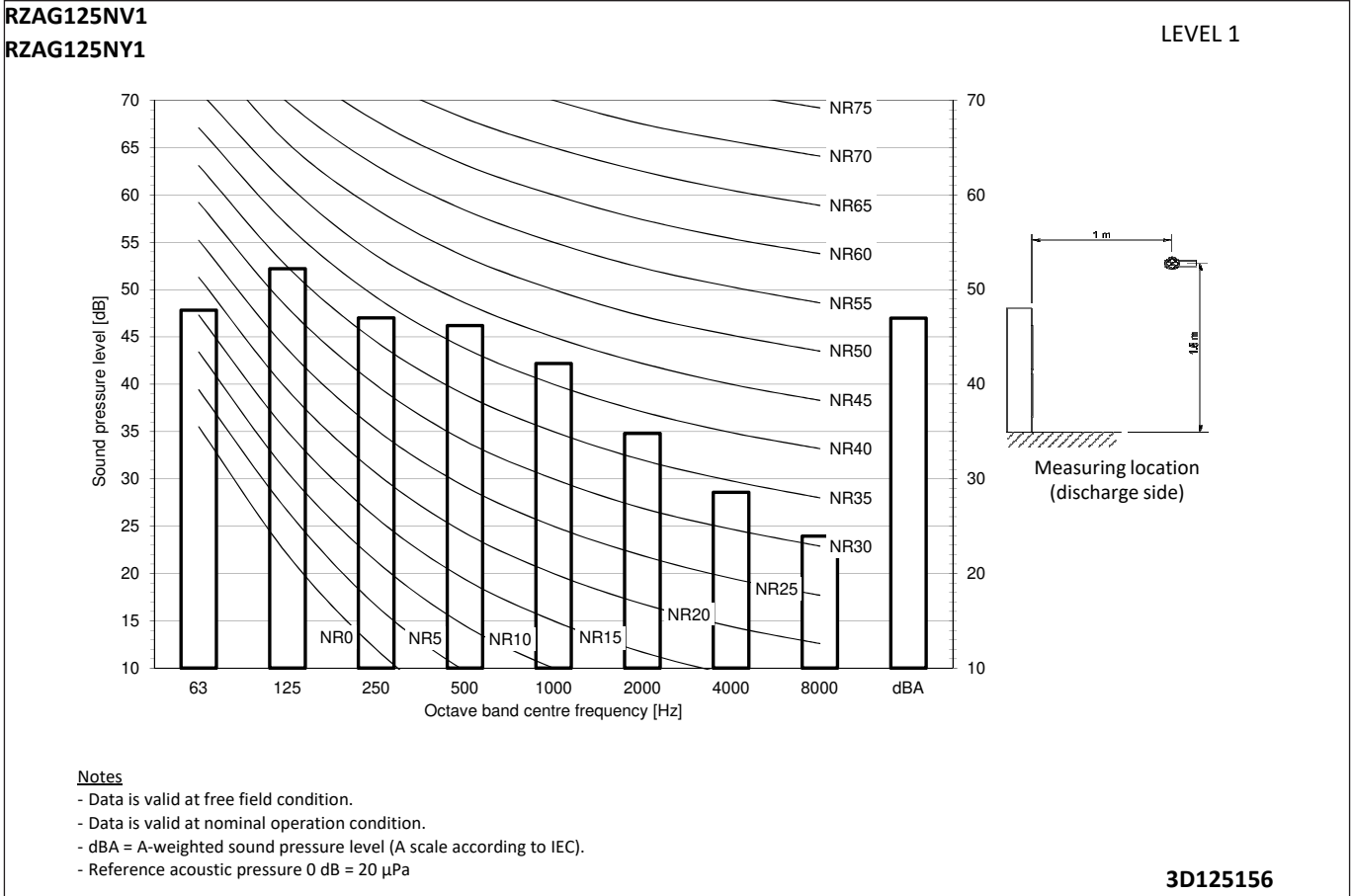

11 Sound data

11 - 5 Sound Pressure Spectrum Quiet Mode Level 2

11

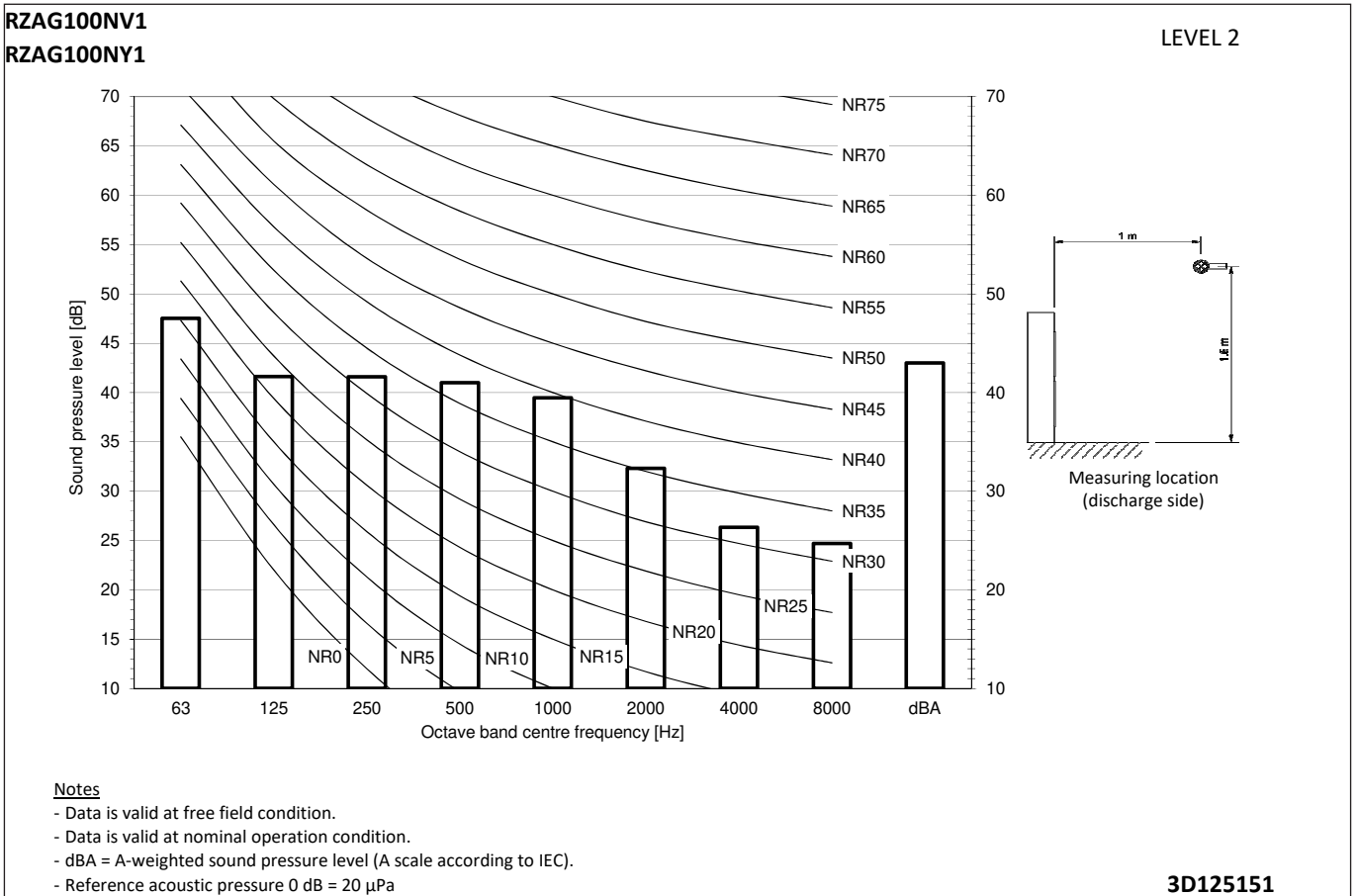
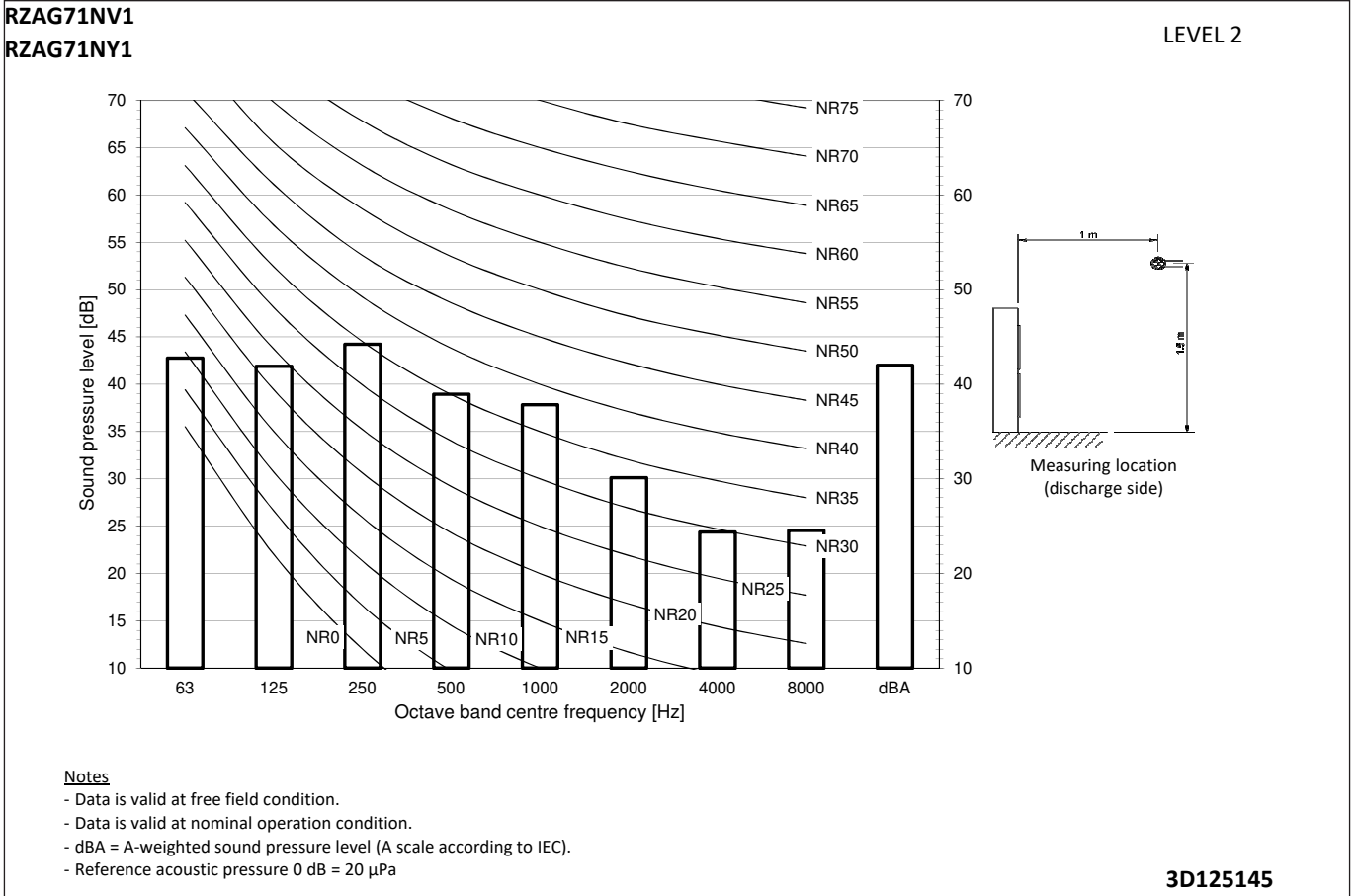

11 Sound data

11 - 5 Sound Pressure Spectrum Quiet Mode Level 2

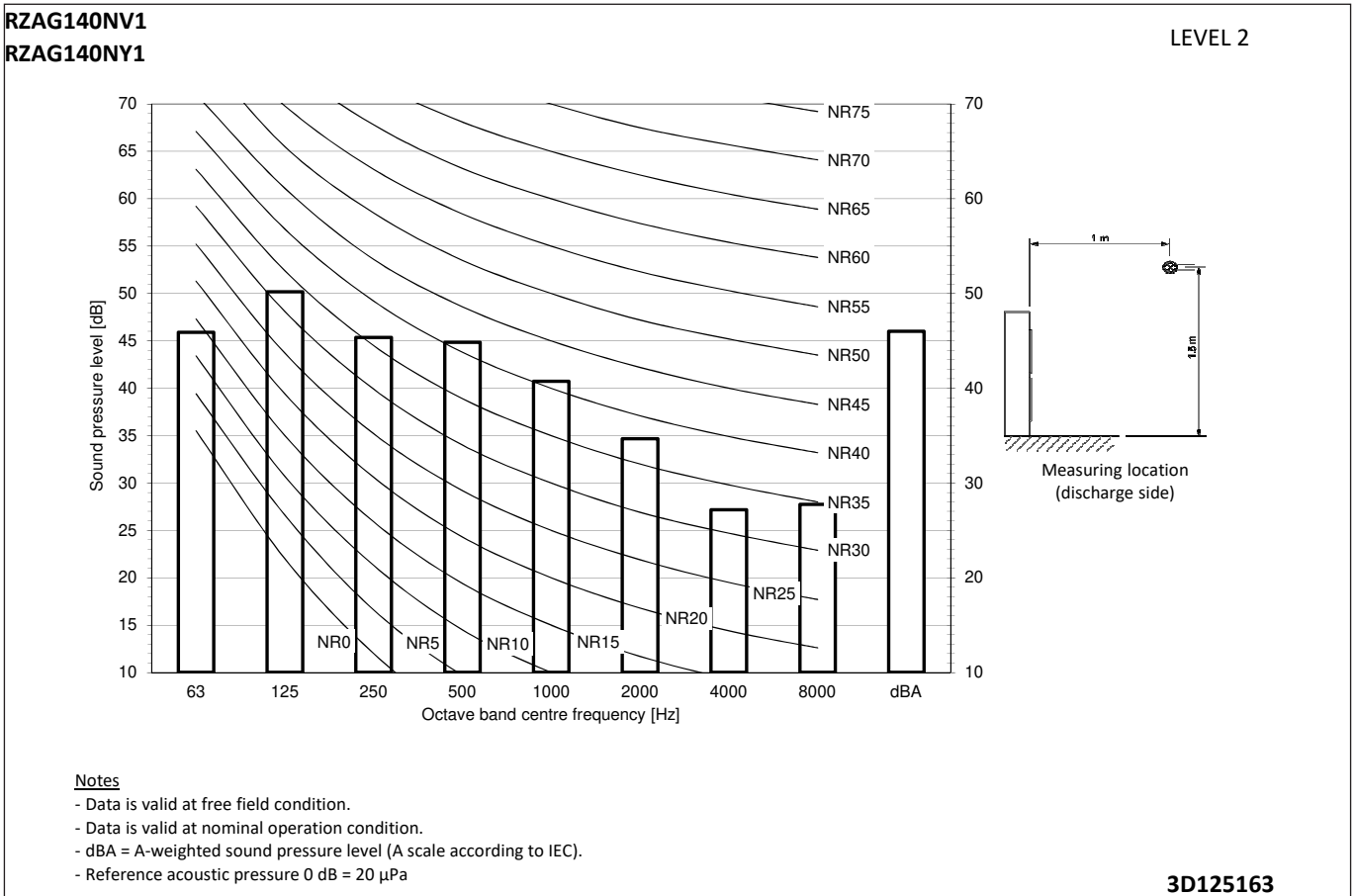
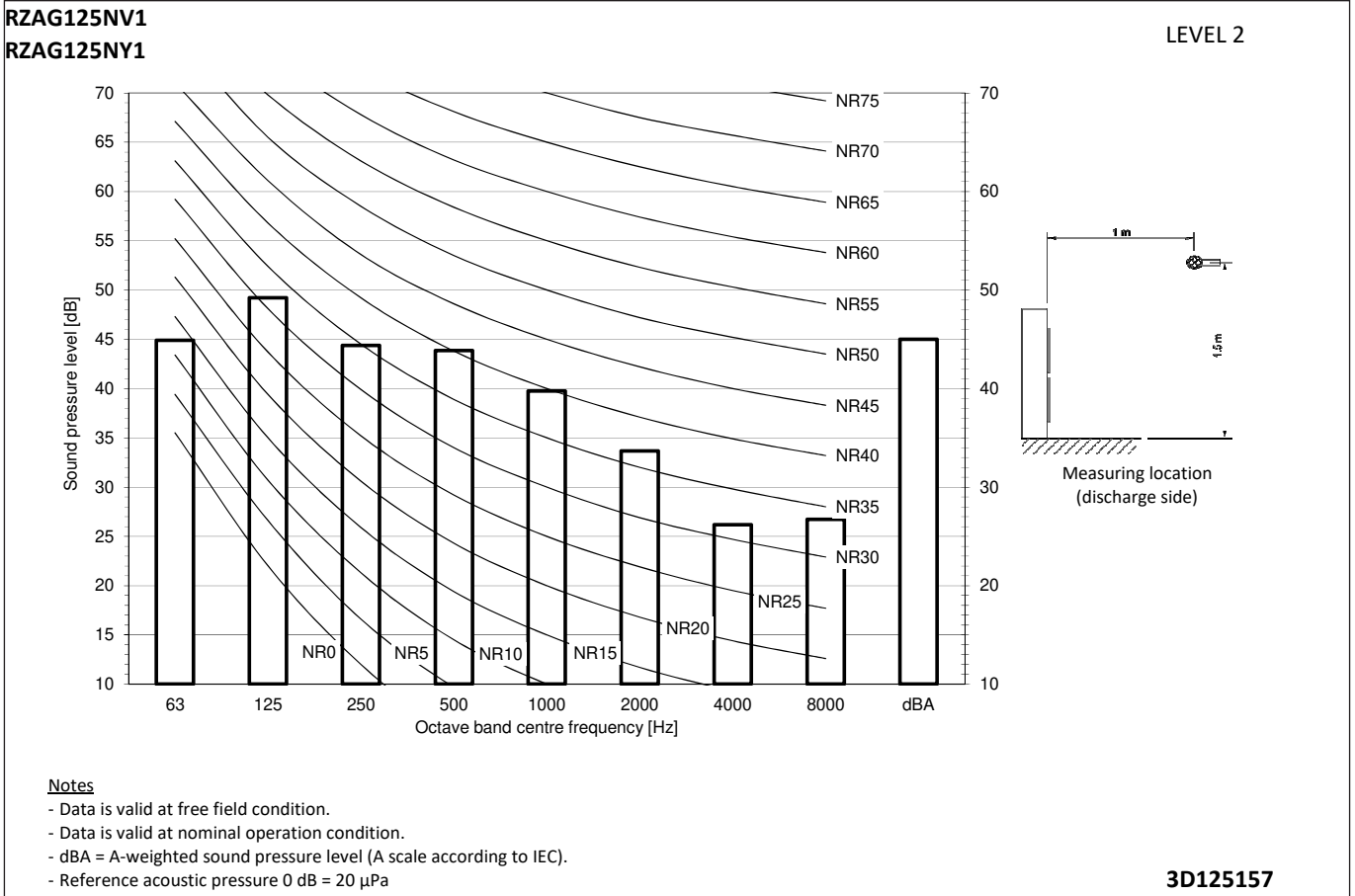

11 Sound data

11 - 6 Sound Pressure Spectrum Quiet Mode Level 3

11

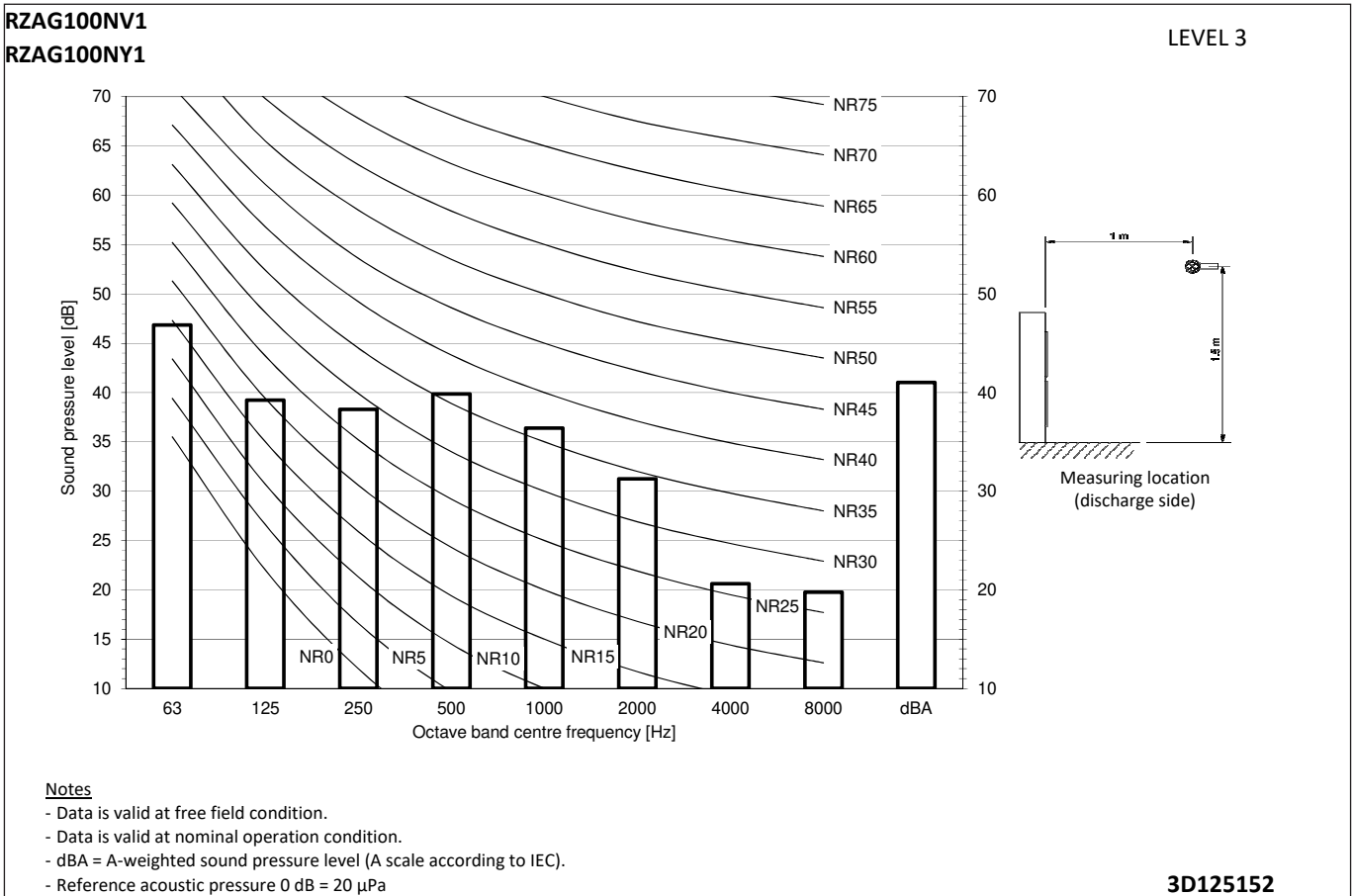
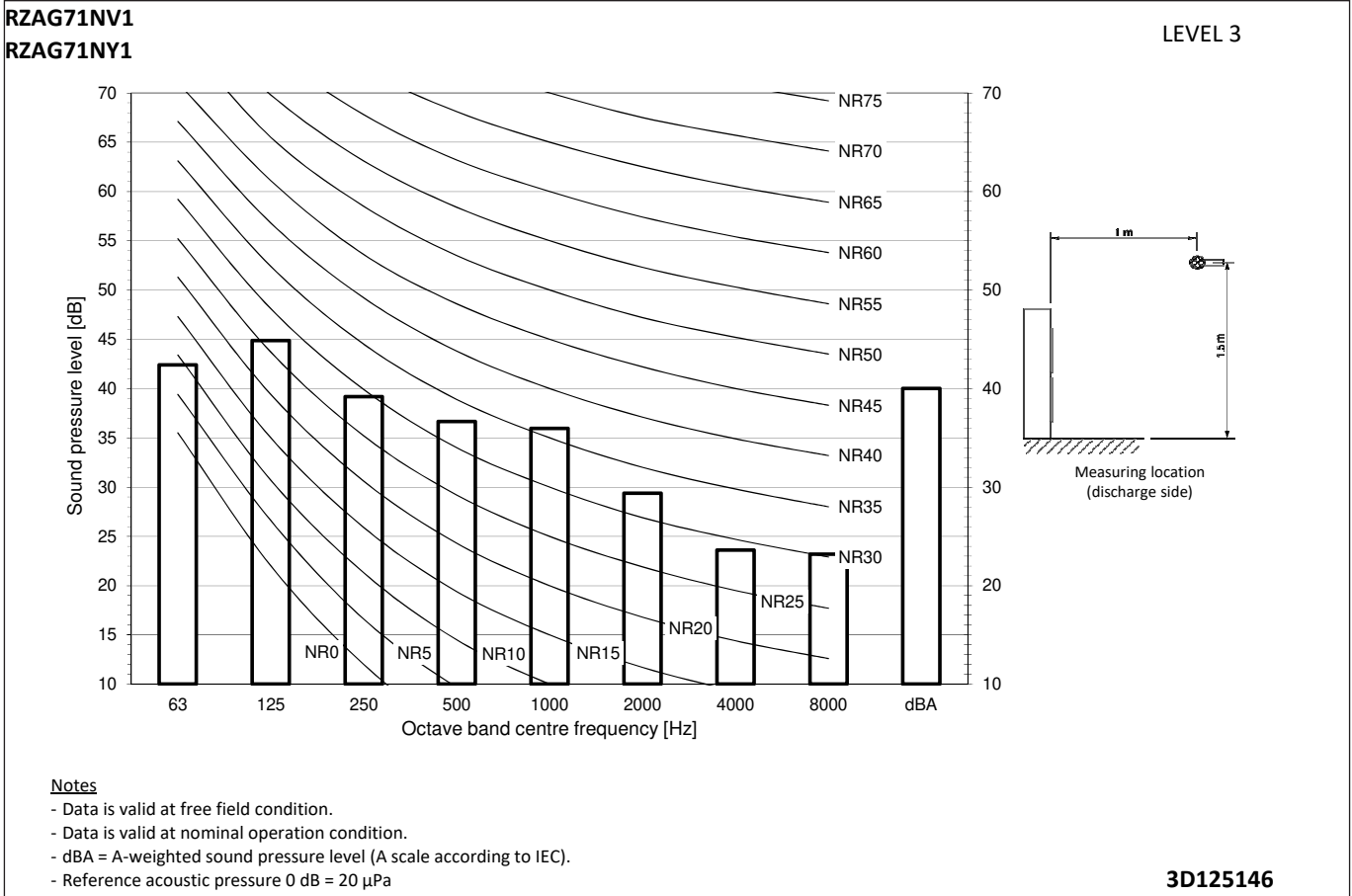

11 Sound data

11 - 6 Sound Pressure Spectrum Quiet Mode Level 3

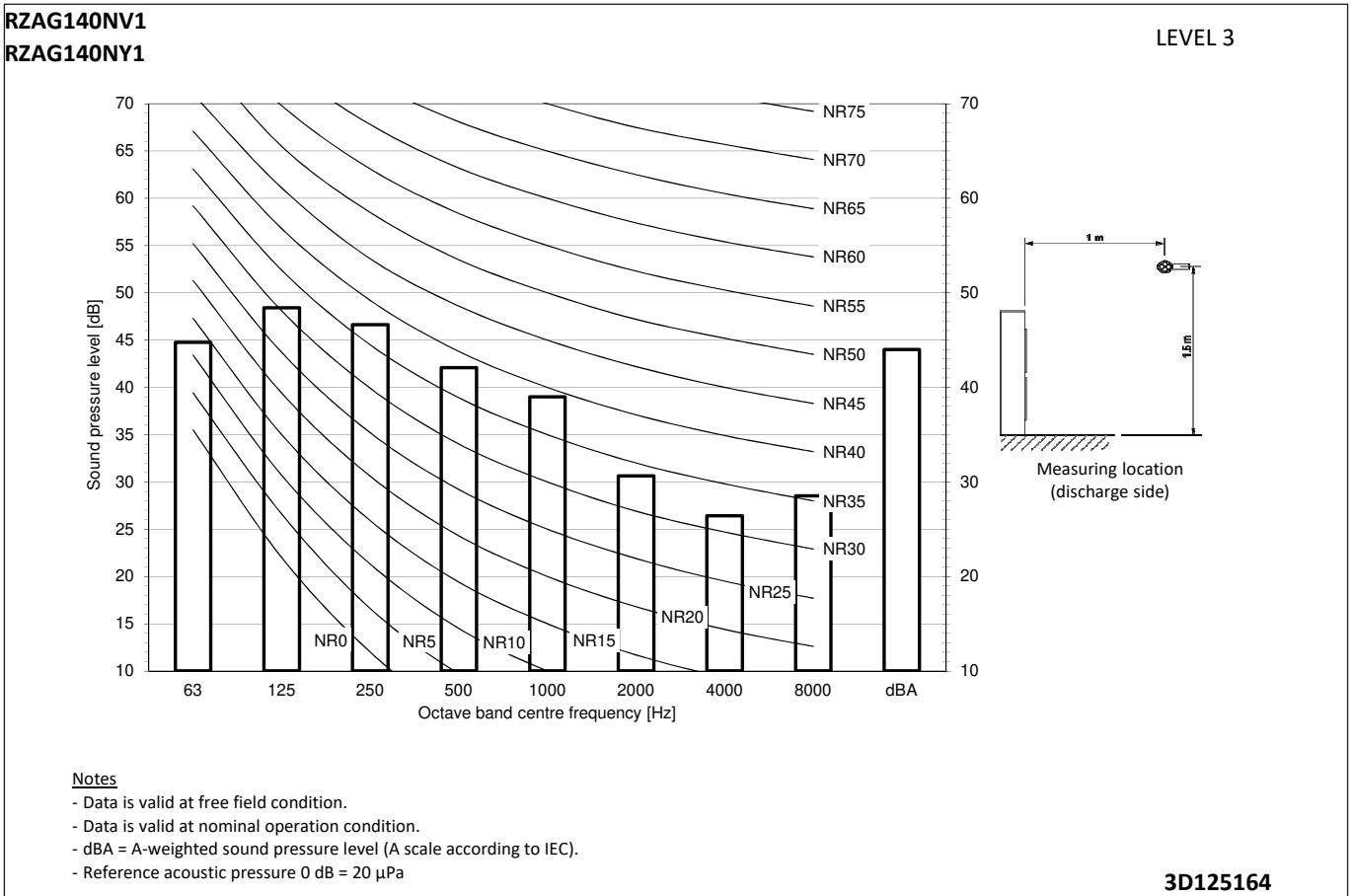
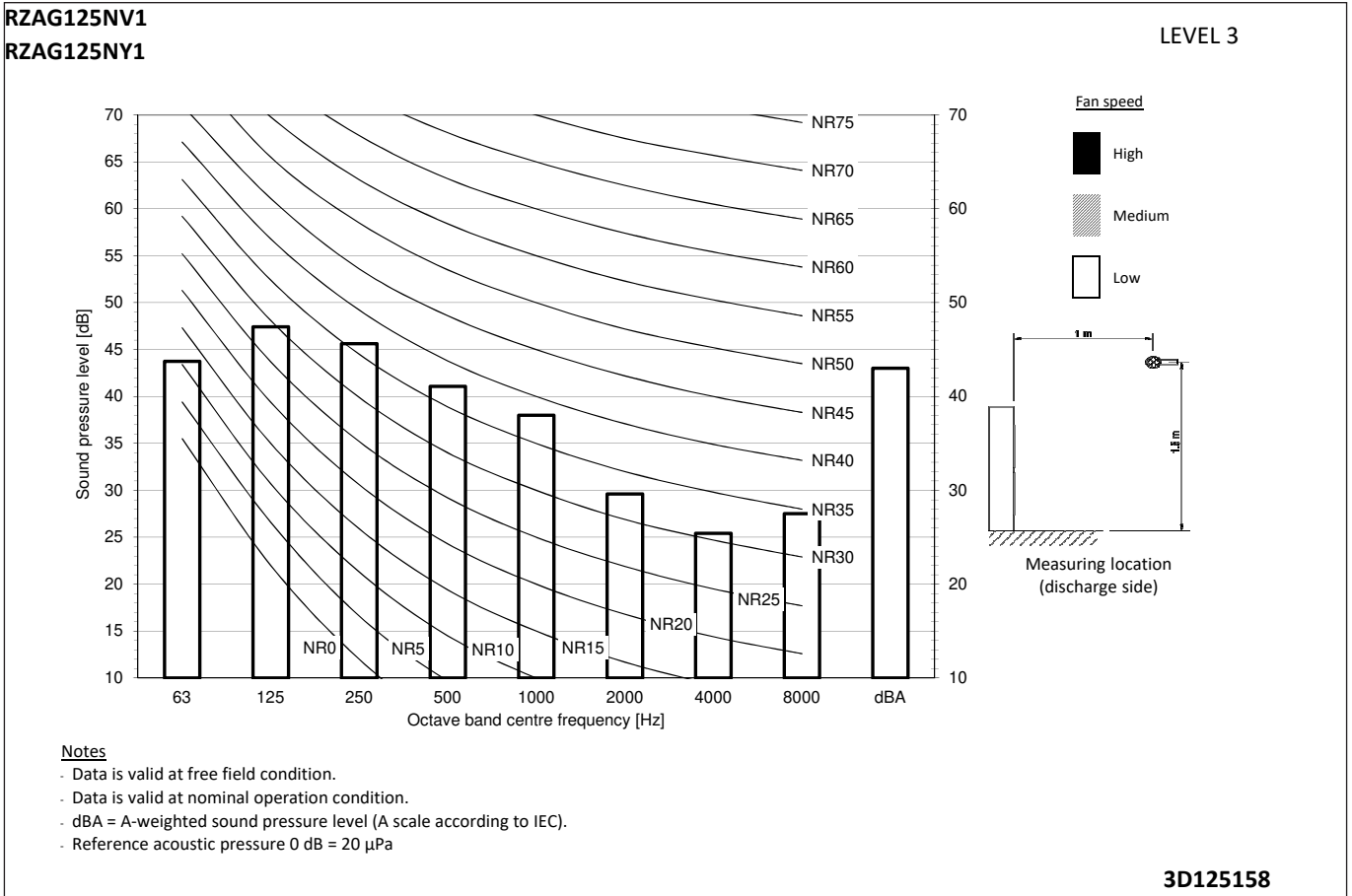

12 Installation

12 - 1 Installation Method

12

RZAG-NV1
RZAG-NY1

Single unit (■) | Single row of units (■ ■ ■)

Suction side

In the illustration below, the service space at the suction side is based on 35°C DB and cooling operation. Foresee more space in the following cases:

- When the suction side temperature regularly exceeds this temperature.
- When the heat load of the outdoor units is expected to regularly exceed the maximum operating capacity.

Discharge side

Take refrigerant piping work into account when positioning the units. If your lay out does not match with any of the layouts below, contact your dealer.

Single unit (■) | Single row of units (■ ■ ■)

	A-E	Hb Hd Hu	(mm)								
			a	b	c	d	e	e _B	e _D		
	B	-		≥ 100							
	A,B,C	-	≥ 100(1)	≥ 100	≥ 100						
	B,E	-		≥ 100			≥ 1000		≤ 500		
	A,B,C,E	-	≥ 150(1)	≥ 150	≥ 150		≥ 1000		≤ 500		
	D	-					≥ 500				
	D,E	-					≥ 500	≥ 1000	≤ 500		
	B,D	Hd > Hu		≥ 100		≥ 500					
			Hd ≤ Hu	≥ 100		≥ 500					
	B,D,E	Hd > Hu	Hb ≤ ½Hu	≥ 250		≥ 750	≥ 1000	≤ 500			1
			½Hu < Hb ≤ Hu	≥ 250		≥ 1000	≥ 1000	≤ 500			
Hb > Hu				⊘							
Hd ≤ Hu		Hd ≤ ½Hu	≥ 100		≥ 1000	≥ 1000	≤ 500				
	½Hu < Hd ≤ Hu	≥ 200		≥ 1000	≥ 1000	≤ 500					
	Hd > Hu				⊘						
	A,B,C	-	≥ 200(1)	≥ 300	≥ 1000						
	A,B,C,E	-	≥ 200(1)	≥ 300	≥ 1000		≥ 1000		≤ 500		
	D	-				≥ 1000					
	D,E	-				≥ 1000	≥ 1000	≤ 500			
	B,D	Hd > Hu		≥ 300		≥ 1000					1+2
			Hd ≤ Hu								
			Hd ≤ ½Hu	≥ 250		≥ 1500					
	B,D,E	Hd > Hu	Hb ≤ ½Hu	≥ 300		≥ 1000	≥ 1000	≤ 500			
			½Hu < Hb ≤ Hu	≥ 300		≥ 1250	≥ 1000	≤ 500			
		Hb > Hu			⊘						
Hd ≤ Hu		Hd ≤ ½Hu	≥ 250		≥ 1500	≥ 1000	≤ 500				
	½Hu < Hd ≤ Hu	≥ 300		≥ 1500	≥ 1000	≤ 500					
	Hd > Hu				⊘						

(1) For better serviceability, use a distance ≥ 250 mm

A,B,C,D Obstacles (walls/baffle plates)

E Obstacle (roof)

a,b,c,d,e Minimum service space between the unit and obstacles A, B, C, D and E

e_B Maximum distance between the unit and the edge of obstacle E, in the direction of obstacle B

e_D Maximum distance between the unit and the edge of obstacle E, in the direction of obstacle D

Hu Height of the unit

Hb,Hd Height of obstacles B and D

1 Seal the bottom of the installation frame to prevent discharged air from flowing back to the suction side through the bottom of the unit.

2 Maximum two units can be installed.

⊘ Not allowed

1D128513

12 Installation

12 - 1 Installation Method

RZAG-NV1
RZAG-NY1

Multiple rows of units ()

Multiple rows of units ()

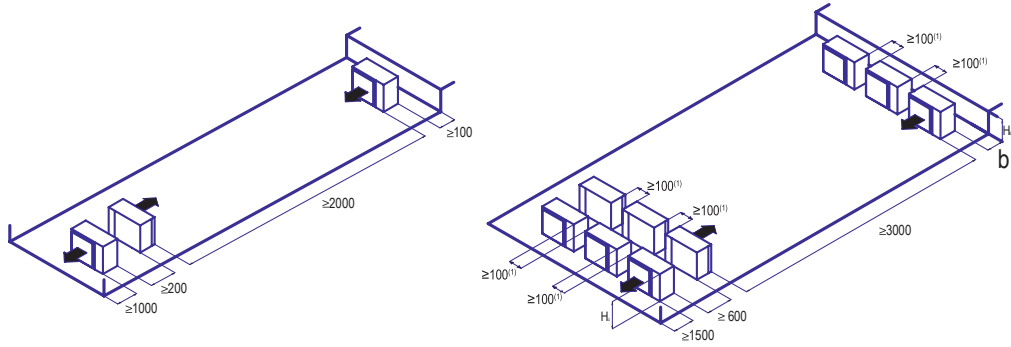

Hb Hu	b (mm)
$Hb \leq \frac{1}{2}Hu$	$b \geq 250$
$\frac{1}{2}Hu < Hb \leq Hu$	$b \geq 300$
$Hb > Hu$	⊘

- (1) For better serviceability, use a distance ≥ 250 mm
- ⊘ Not allowed

1D128513

12 Installation

12 - 1 Installation Method

12

RZAG-NV1
RZAG-NY1

Stacked units (max.2 levels) 

Stacked units (max.2 levels) 

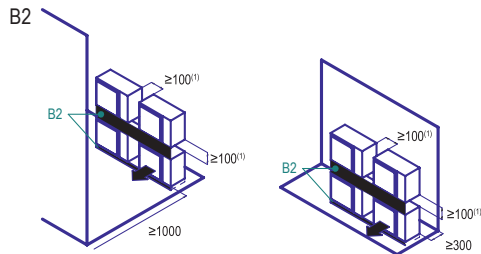
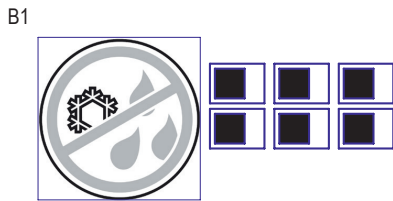
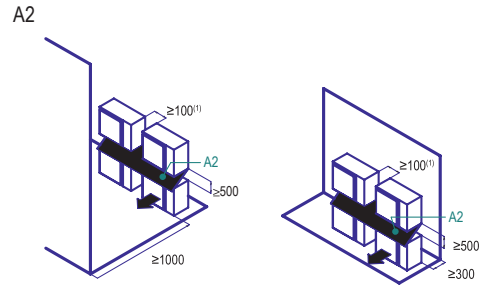
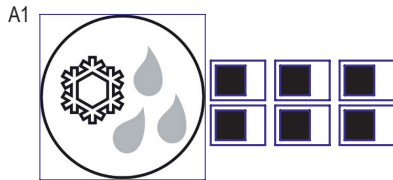

- (1) For better serviceability, use a distance ≥ 250 mm
- A1=>A2 (A1) If there is danger of drainage dripping and freezing between the upper and lower units...
- (A2) Then install a roof between the upper and lower units. Install the upper unit high enough above the lower unit to prevent ice buildup at the upper unit's bottom plate.
- B1=>B2 (B1) If there is no danger of drainage dripping and freezing between the upper and lower units...
- (B2) Then it is not required to install a roof, but seal the gap between the upper and lower units to prevent discharged air from flowing back to the suction side through the bottom of the unit.

1D128513

13 Operation range

13 - 1 Operation Range

RZAG-NV1 RZAG-NY1

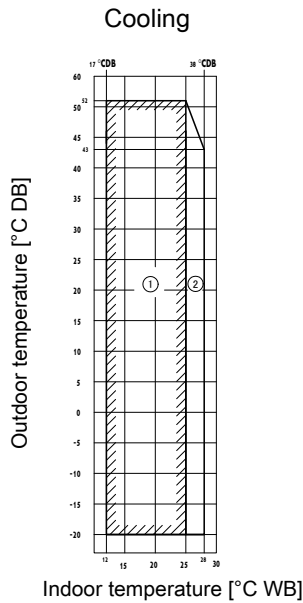

- ① Operation range
- ② Pull-down operation range
- ③ Warm-up operation range

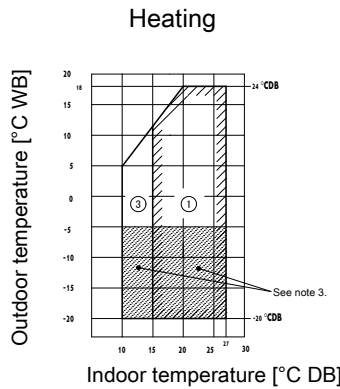

Notes

1. Depending on operation and installation conditions, the indoor unit can change over to freeze-up operation (indoor de-icing).
2. To reduce the freeze-up operation (indoor de-icing) frequency, it is recommended to install the outdoor unit in a location not exposed to wind.
3. If the unit is selected to operate at ambient temperature < -5°C for 5 days or more, with relative humidity of 100%, it is required to install the optional bottom plate heater.

3D110020A

RZAG-NV1 RZAG-NY1

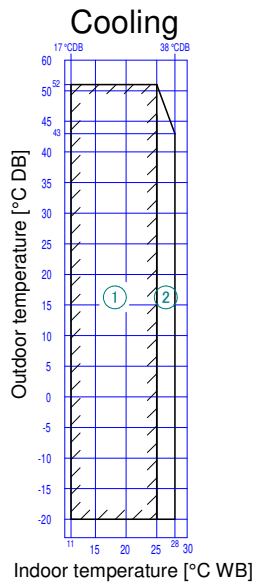

- ① Operation range
- ② Pull-down operation range
- ③ Warm-up operation range

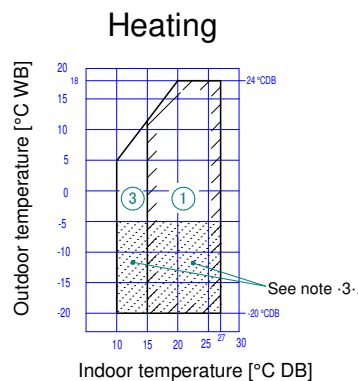

Notes

1. Depending on operation and installation conditions, the indoor unit can change over to freeze-up operation (indoor de-icing).
2. To reduce the freeze-up operation (indoor de-icing) frequency, it is recommended to install the outdoor unit in a location not exposed to wind.
3. If the unit is selected to operate at ambient temperature < -5°C for -5- days or more, with relative humidity of 100%, it is required to install the optional bottom plate heater.

3D110022

14 Appropriate Indoors

14 - 1 Appropriate Indoors

RZAG125-140NV1

RZAG125-140NY1

ENER Lot 21

Recommended combinations

Sky Air		High Cassette				Thin cassette				2x2 cassette			Duct (medium ESP)			Concealed floor standing type			Ceiling-mounted - 4-way blow			Wall mounted type		Duct (high ESP)								
Model		FCAHG71	FCAHG100	FCAHG125	FCAHG140	FCAG35	FCAG50	FCAG60	FCAG71	FCAG100	FCAG125	FCAG140	FFA35	FFA50	FFA60	FBA35	FBA50	FBA60	FBA71	FBA100	FBA125	FBA140	FNA35	FNA50	FNA60	FUA71	FUA100	FUA125	FAA71	FAA100	FDA125	
RZAG125N*V1B	RZAG125N*Y1B			P		4										4																P
RZAG140N*V1B	RZAG140N*Y1B				P	4						P				4																

Sky Air		Floor standing type				Slim duct			Ceiling-suspended						Floor standing type	
Model		FVA71	FVA100	FVA125	FVA140	FDXM35	FDXM50	FDXM60	FHA35	FHA50	FHA60	FHA71	FHA100	FHA125	FHA140	AVA125
RZAG125N*V1B	RZAG125N*Y1B			P												P
RZAG140N*V1B	RZAG140N*Y1B				P											P

4D140340A

RZASG125-140NV1

RZASG125-140NY1

ENER Lot 21

Appropriate indoor units

Connectable to ·RZAG125N*V1B/RZAG125N*Y1B· and covered by ·ENER Lot 21·

FCAHG125	FCAG35	FFA35	FBA35	FNA35	FUA125	-	FDA125	FVA125	FDXM35	FHA35	-
-	FCAG50	FFA50	FBA50	FNA50	-	-	-	-	FDXM50	FHA50	-
-	FCAG60	FFA60	FBA60	FNA60	-	-	-	-	FDXM60	FHA60	-
-	FCAG125	-	FBA125	-	-	-	-	-	-	FHA125	-

Connectable to ·RZAG140N*V1B/RZAG140N*Y1B· and covered by ·ENER Lot 21·

FCAHG71	FCAG35	FFA35	FBA35	FNA35	FUA71	FAA71	-	FVA71	FDXM35	FHA35	-
FCAHG140	FCAG50	FFA50	FBA50	FNA50	-	-	-	FVA140	FDXM50	FHA50	-
-	FCAG71	-	FBA71	-	-	-	-	-	-	FHA71	-
-	FCAG140	-	FBA140	-	-	-	-	-	-	FHA140	-

4D140340A

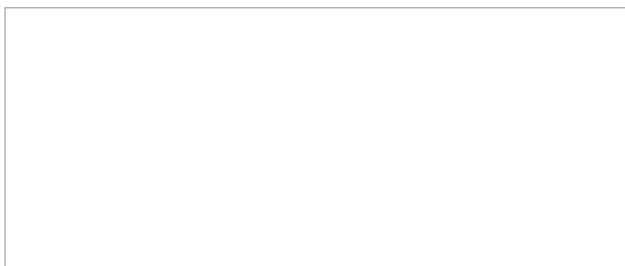

EEDEN24

06/2024



The present leaflet is drawn up by way of information only and does not constitute an offer binding upon Daikin Europe N.V. Daikin Europe N.V. has compiled the content of this leaflet to the best of its knowledge. No express or implied warranty is given for the completeness, accuracy, reliability or fitness for particular purpose of its content and the products and services presented therein. Specifications are subject to change without prior notice. Daikin Europe N.V. explicitly rejects any liability for any direct or indirect damage, in the broadest sense, arising from or related to the use and/or interpretation of this leaflet. All content is copyrighted by Daikin Europe N.V.